

Product Catalogue

HEADQUARTERS:

Located: Plot 91-93, 6th Street Industrial Area,
Kampala, Uganda
Email: giant.uganda@gmail.com
Tel: +256 200 905 484
Open: Mon - Fri: 08:30- 05:30
Sat: 08:30- 02:00

JINJA BRANCH:

Located: Plot 11-17 Kigenyi Naluwairo Rd Jinja,
P.O.Box 1759 Jinja, Uganda.
Email: info@giantuganda.co.ug
Tel: +256 200 905 484
Open: Mon - Sat: 09:00 - 18:00



GIANT UGANDA CO.LTD.



GIANT UGANDA CO.LTD



GIANT UGANDA CO. LTD

www.giantuganda.co.ug

Factory at Jinja

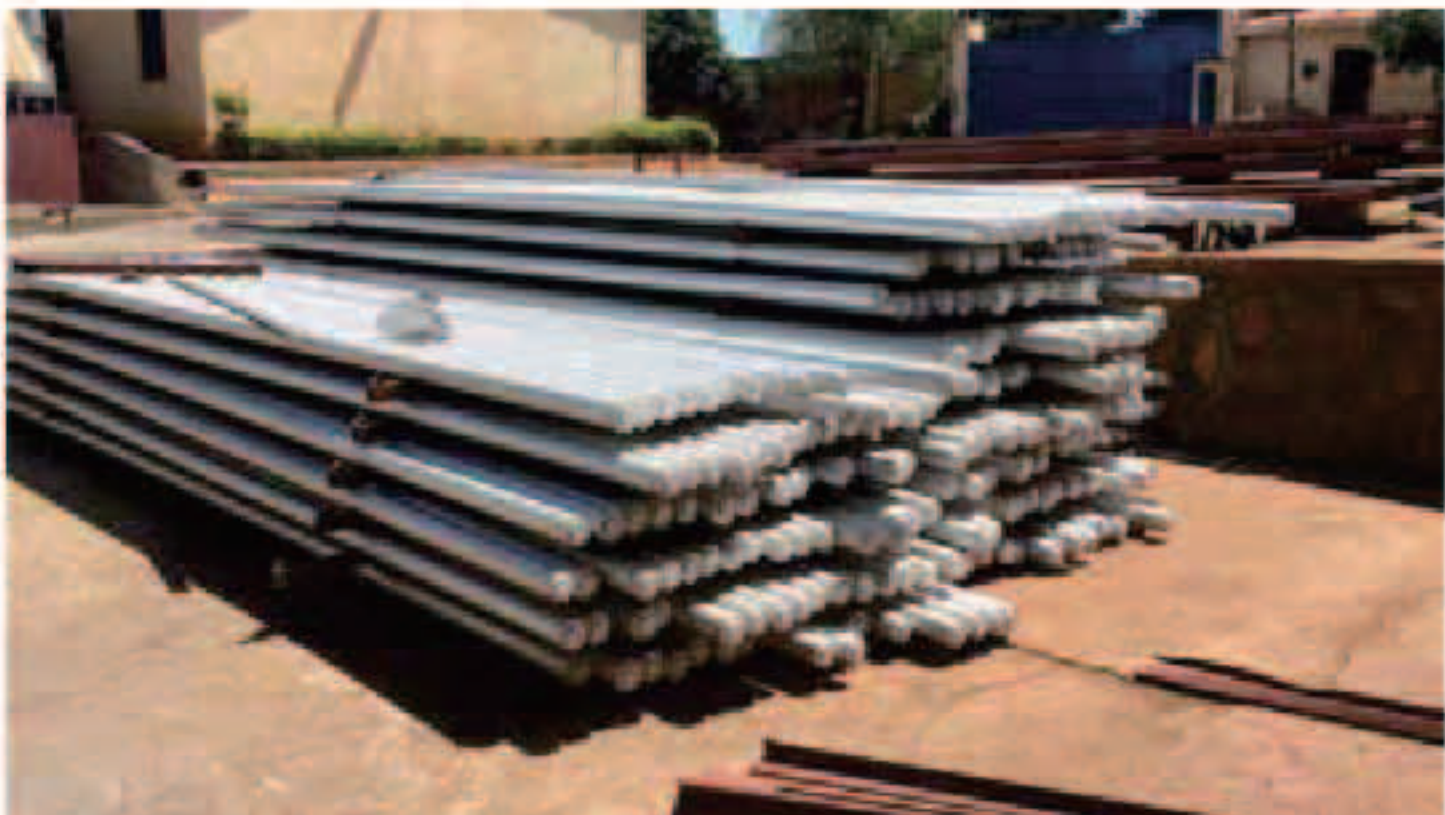

GIANT UGANDA CO. LTD

www.giantuganda.co.ug

COMPANY PROFILE

Giant Uganda Company Ltd. is the pilot of aluminum industries. We own the whole production procedures from aluminum profile R&D, molding, aluminum profile produce, surface treatment, to the aluminum windows, doors, partitions, glass curtain wall installation.

As the no. 1 aluminum profile manufacturer in East Africa we have various supporting dies and the up to date casting workshop, 1000 tons extruding lines, anodizing plant, powder coating plant and other modernization production facilities and power support. Ensure our annually aluminum profiles production capacity up to 25,000 tons. professional engineers and nearly 200 skilled workers plus our complete management systems. we can provide our esteemed customers good quality aluminum profiles @ competitive price. We are not only supply aluminum profiles but also undertake the installation engineering. Our products are hot sale at Uganda inner market & neighboring countries such as Rwanda, Congo, South Arica, Kenya, Tanzania, etc. We welcome all customers to visit our factory and office for mutually co-operation and double win.



CHAIRMAN'S SPEECH

There is an old saying in Chinese : Carving something while giving up halfway, Deadwood can't be carved, but if we persevere in carving, Metal and stones are able to be shaped well. The meaning of "persistence" on our Giant Aluminum performance is particularly important, Nearly 10 years development. It developed from a few workers in a factory to nearly 200 staff's enterprises.

The Giant becomes a professional Aluminum profile manufacturer, which has a complete set of production systems from R&D. Producing, Sales, Processing to installation besides it is making a huge effect in this industry even throughout Africa. The stable sales network covering the whole country & neighboring countries & regions. The achievement of Giant today attribute to that we always adhere to the philosophy of "Quality First, Reputation First, Customer First", Earnestly implement the quality policy of, "Quality is much heavier than mountains, Customer satisfaction above all else", and abide the commitment of honestly managing company.

Meanwhile, as a foreign company, we got a lot of local government support & Customer's trust & love. Here, I give all my heartfelt thanks to all of you on behalf of all the staffs ! Reviewing the past, we have lofty sentiments : looking to the future, we are full of confidence, we will exert our advantages, ally the strength, and mobilize enthusiasm of staff in order to make the company more powerful. By all these efforts, the Giant Aluminum will become a modern enterprise with powerful strength. Broad prospects, a galaxy of talents & harmonious development.

POWDER COATING QUALICOAT QUALITY LEVEL & EUROPE STANDARD TABLE

Item	Test	Qualicoat (Standard)	XINHE Standard
Gloss	ISO2813 GB/T9754	L-G: +5 M-G: +7 H-G: +10	L-G: +5 M-G: +7 H-G: +10
Thickness of Coatings	ISO2360 GB/T4957	Average of five points is not less than 60um	Average of five points is not less than 60um
Adhesion	ISO2409 GB/T9286	Grade to O	Grade to O
Erichsen Cupping Test	ISO1520 GB/T9573	5mm	6mm, no crack
Impact Test	ASTMD2794 GB/T1732	2.5NM	5.5NM, no crack
Hardest Test	ISO2815 GB/T6739	80 at least	Not less than H
Resistance to Cracking on bending	ISO1519 GB/T6742	5mm	5.5mm, no crack
Mortar Resistance	ASTMC-207 GB/T1594	The mortar must be easy to remove without leaving any residues.	No visible change no removal
Acid Test	AAMA 2603	Eroding within 0.5mm offlineation	No forth, goffer or removal
Salt Spray Resistance	ISO9927 GB/T10125	1000 hrs	1000 hrs, eroding within 2mm of lineation
Resistance to boiling water	AAMA 2603	1 hrs	1hrs, no air bubble, goffer, water spot or removal vice
Accelerated weathering Test	DIN553231 Suntest GB/T1865-97	1000hrs, the loss of gloss must not be more than 50%	Good
Solvent Resistance	DIN50017 GB1740	1000 hrs	Good
Gloss	AAMA 2603		1hrs, no air bubble, goffer, water spot or removal vice
Color Test			$\Delta E^*ab \leq 1.5$

GENERAL CHEMICAL COMPOSITION OF ALLOY

Alloy	6061(%)	6063(%)	6063A(%)
Si	0.40-0.80	0.20-0.60	0.30-0.60
Fe	0.7	0.35	0.15-0.35
Cu	0.15-0.40	0.10	0.10
Mn	0.15	0.10	0.15
Mg	0.80-1.20	0.45-0.90	0.60-0.90
Cr	0.04-0.35	0.10	0.05
Zn	0.25	0.10	0.15
Ti	0.15	0.10	0.10
Others (each)	0.05	0.05	0.05
Others (total)	0.15	0.15	0.15
Al	Rema inder	Rema inder	Rema inder

Oxidization of Aluminum Profile Finishing

Class	Min-acerg film thickness	Min-part film thickness
AA10	10	8
AA15	15	12
AA20	20	16
AA25		25

Mechanical Properties of Sections under Room Temperature

Alloy	State	Tensile Strength Test			Hardness Test		
		Tensile Strength σ_b Mpa	Non-proportional Stretching Stress	Stretching Rate	Pattern Thickness	HV	HW
			(δ 0.2Mpa)	(δ %)	(mm)		
No less than (\geq)							
6061	T4	180	110	16	-	-	-
	T6	245	245	8	-	-	-
6063	T5	110	110	8	0.8	58	8
	T6	180	180	8	-	-	-
6063A	T5	160	160	5	0.8	65	10
		150	150	5			
	T6	190	190	5	-		
		180	180	4			

TABLE OF CONTENTS

Sr.No	CONTENTS	Page No
1	80/88 SLIDING DOOR/WINDOW	1--3
2	2001 LUXURY SLIDNG DOOR/WINDOW	4--5
3	GT90 SLIDNG DOOR/WINDOW SERIES	6--7
4	TWO RAIL/TAREE RAIL SLIDING DOOR SERIES	8
5	GT08 SERIES	9-11
6	300/90 SERIES FOR PROJECTION	12
7	40/50 SERIES FOR PROJECTION	13-14
8	PARTITION SERIES	15-18
9	46 COLUMN DOOR SERTES	19
10	76 COLUMN DOOR SERTES	20
11	CURTAIN WALL SERIES	21-24
12	ROLLER SHUTTER SERIES/SLIDING NET	25
13	FOLDING DOOR	26-27
14	BALCONY RAILING/HANDRAIL PROFILE	28
15	ALUMINIUM BURGLAR PROOF	29
16	CONNECTION SERIES	30-32
17	HOLLOW SECTION SERIES	33-34
18	CAL SERIES	35-36
19	COLOR CARD	37-40
20	ACCESSORIES	41-50

80/88 SL IDING DOOR/WINDOW

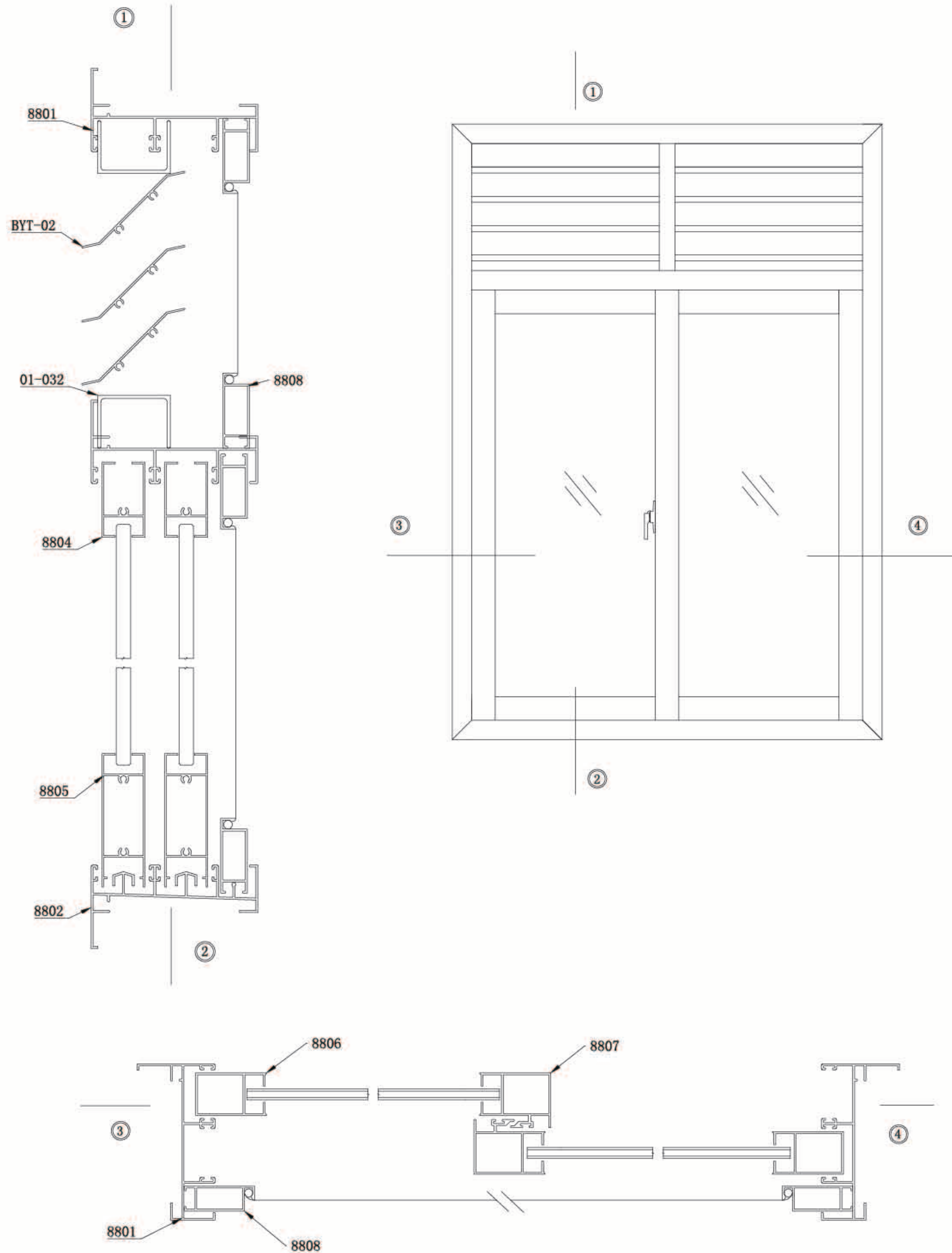

80/88 SL IDING DOOR/WINDOW

Item No	Thickness	Weight(Kg/6.4m)	Item No	Thickness	Weight(Kg/6.4m)	Item No	Thickness	Weight(Kg/6.4m)																		
包框下滑 BOTTOM 			包框上滑 TOP/SIDEFRAME 			光企 LOCKING 																				
53-01	1.1	5.8	53-02	1.1	5.2	53-03	1.0	2.3																		
勾企 INTER LOCK 			上下方 TOP/BOTTOM-SHUTTER 			上滑 TOP/SIDE FRAME 																				
53-04	1.0	2.6	53-05	1.0	2.5	53-06	1.1	3.9																		
下滑 BOTTOM 			纱窗料 NET 																							
53-07	1.1	5.4	53-08	1.2	1.9																					
<table border="1"> <thead> <tr> <th>Item No</th> <th>Thickness</th> <th>Weight(Kg/6.4m)</th> </tr> </thead> <tbody> <tr> <td></td> <td></td> <td></td> </tr> </tbody> </table>			Item No	Thickness	Weight(Kg/6.4m)				<table border="1"> <thead> <tr> <th>Item No</th> <th>Thickness</th> <th>Weight(Kg/6.4m)</th> </tr> </thead> <tbody> <tr> <td></td> <td></td> <td></td> </tr> </tbody> </table>			Item No	Thickness	Weight(Kg/6.4m)				<table border="1"> <thead> <tr> <th>Item No</th> <th>Thickness</th> <th>Weight(Kg/6.4m)</th> </tr> </thead> <tbody> <tr> <td></td> <td></td> <td></td> </tr> </tbody> </table>			Item No	Thickness	Weight(Kg/6.4m)			
Item No	Thickness	Weight(Kg/6.4m)																								
Item No	Thickness	Weight(Kg/6.4m)																								
Item No	Thickness	Weight(Kg/6.4m)																								
<table border="1"> <thead> <tr> <th>Item No</th> <th>Thickness</th> <th>Weight(Kg/6.4m)</th> </tr> </thead> <tbody> <tr> <td></td> <td></td> <td></td> </tr> </tbody> </table>			Item No	Thickness	Weight(Kg/6.4m)				<table border="1"> <thead> <tr> <th>Item No</th> <th>Thickness</th> <th>Weight(Kg/6.4m)</th> </tr> </thead> <tbody> <tr> <td></td> <td></td> <td></td> </tr> </tbody> </table>			Item No	Thickness	Weight(Kg/6.4m)				<table border="1"> <thead> <tr> <th>Item No</th> <th>Thickness</th> <th>Weight(Kg/6.4m)</th> </tr> </thead> <tbody> <tr> <td></td> <td></td> <td></td> </tr> </tbody> </table>			Item No	Thickness	Weight(Kg/6.4m)			
Item No	Thickness	Weight(Kg/6.4m)																								
Item No	Thickness	Weight(Kg/6.4m)																								
Item No	Thickness	Weight(Kg/6.4m)																								

80/88 SL IDING DOOR/WINDOW

<p>包框上滑 TOP/SIDEFRAME</p>	<p>包框下滑 BOTTOM</p>	<p>上方 TOP SHUTTER</p>																		
<table border="1"> <thead> <tr> <th>Item No</th> <th>Thickness</th> <th>Weight (Kg/6.4m)</th> </tr> </thead> <tbody> <tr> <td>8801</td> <td>1.2</td> <td>6.1</td> </tr> </tbody> </table>	Item No	Thickness	Weight (Kg/6.4m)	8801	1.2	6.1	<table border="1"> <thead> <tr> <th>Item No</th> <th>Thickness</th> <th>Weight (Kg/6.4m)</th> </tr> </thead> <tbody> <tr> <td>8802</td> <td>1.2</td> <td>7.9</td> </tr> </tbody> </table>	Item No	Thickness	Weight (Kg/6.4m)	8802	1.2	7.9	<table border="1"> <thead> <tr> <th>Item No</th> <th>Thickness</th> <th>Weight (Kg/6.4m)</th> </tr> </thead> <tbody> <tr> <td>8804</td> <td>1.2</td> <td>3.3</td> </tr> </tbody> </table>	Item No	Thickness	Weight (Kg/6.4m)	8804	1.2	3.3
Item No	Thickness	Weight (Kg/6.4m)																		
8801	1.2	6.1																		
Item No	Thickness	Weight (Kg/6.4m)																		
8802	1.2	7.9																		
Item No	Thickness	Weight (Kg/6.4m)																		
8804	1.2	3.3																		
<p>下方 BOTTOM-SHUTTER</p>	<p>光企 LOCKING</p>	<p>勾企 INTER LOCK</p>																		
<table border="1"> <thead> <tr> <th>Item No</th> <th>Thickness</th> <th>Weight (Kg/6.4m)</th> </tr> </thead> <tbody> <tr> <td>8805</td> <td>1.2</td> <td>5.4</td> </tr> </tbody> </table>	Item No	Thickness	Weight (Kg/6.4m)	8805	1.2	5.4	<table border="1"> <thead> <tr> <th>Item No</th> <th>Thickness</th> <th>Weight (Kg/6.4m)</th> </tr> </thead> <tbody> <tr> <td>8806</td> <td>1.2</td> <td>3.4</td> </tr> </tbody> </table>	Item No	Thickness	Weight (Kg/6.4m)	8806	1.2	3.4	<table border="1"> <thead> <tr> <th>Item No</th> <th>Thickness</th> <th>Weight (Kg/6.4m)</th> </tr> </thead> <tbody> <tr> <td>8807</td> <td>1.2</td> <td>4.2</td> </tr> </tbody> </table>	Item No	Thickness	Weight (Kg/6.4m)	8807	1.2	4.2
Item No	Thickness	Weight (Kg/6.4m)																		
8805	1.2	5.4																		
Item No	Thickness	Weight (Kg/6.4m)																		
8806	1.2	3.4																		
Item No	Thickness	Weight (Kg/6.4m)																		
8807	1.2	4.2																		
<p>上滑 TOP/SIDEFRAME</p>	<p>下滑 BOTTOM</p>	<p>包框上滑 TOP/SIDE</p>																		
<table border="1"> <thead> <tr> <th>Item No</th> <th>Thickness</th> <th>Weight (Kg/6.4m)</th> </tr> </thead> <tbody> <tr> <td>8801A</td> <td>1.2</td> <td>5.4</td> </tr> </tbody> </table>	Item No	Thickness	Weight (Kg/6.4m)	8801A	1.2	5.4	<table border="1"> <thead> <tr> <th>Item No</th> <th>Thickness</th> <th>Weight (Kg/6.4m)</th> </tr> </thead> <tbody> <tr> <td>8802A</td> <td>1.2</td> <td>7.0</td> </tr> </tbody> </table>	Item No	Thickness	Weight (Kg/6.4m)	8802A	1.2	7.0	<table border="1"> <thead> <tr> <th>Item No</th> <th>Thickness</th> <th>Weight (Kg/6.4m)</th> </tr> </thead> <tbody> <tr> <td>8801B</td> <td>1.2</td> <td>4.3</td> </tr> </tbody> </table>	Item No	Thickness	Weight (Kg/6.4m)	8801B	1.2	4.3
Item No	Thickness	Weight (Kg/6.4m)																		
8801A	1.2	5.4																		
Item No	Thickness	Weight (Kg/6.4m)																		
8802A	1.2	7.0																		
Item No	Thickness	Weight (Kg/6.4m)																		
8801B	1.2	4.3																		
<p>包框下滑 BOTTOM</p>	<p>收口 ADAPTOR</p>	<p>中横 TRANSOME</p>																		
<table border="1"> <thead> <tr> <th>Item No</th> <th>Thickness</th> <th>Weight (Kg/6.4m)</th> </tr> </thead> <tbody> <tr> <td>8802B</td> <td>1.2</td> <td>4.8</td> </tr> </tbody> </table>	Item No	Thickness	Weight (Kg/6.4m)	8802B	1.2	4.8	<table border="1"> <thead> <tr> <th>Item No</th> <th>Thickness</th> <th>Weight (Kg/6.4m)</th> </tr> </thead> <tbody> <tr> <td>8811</td> <td>1.4</td> <td>2.1</td> </tr> </tbody> </table>	Item No	Thickness	Weight (Kg/6.4m)	8811	1.4	2.1	<table border="1"> <thead> <tr> <th>Item No</th> <th>Thickness</th> <th>Weight (Kg/6.4m)</th> </tr> </thead> <tbody> <tr> <td>8812</td> <td>1.2</td> <td>4.4</td> </tr> </tbody> </table>	Item No	Thickness	Weight (Kg/6.4m)	8812	1.2	4.4
Item No	Thickness	Weight (Kg/6.4m)																		
8802B	1.2	4.8																		
Item No	Thickness	Weight (Kg/6.4m)																		
8811	1.4	2.1																		
Item No	Thickness	Weight (Kg/6.4m)																		
8812	1.2	4.4																		
<p>纱窗料 NET</p>	<p>百叶框 LOOVER CHANNEL</p>	<p>U槽 LOOVERCHANNEL</p>																		
<table border="1"> <thead> <tr> <th>Item No</th> <th>Thickness</th> <th>Weight (Kg/6.4m)</th> </tr> </thead> <tbody> <tr> <td>8808</td> <td>1.2</td> <td>2.8</td> </tr> </tbody> </table>	Item No	Thickness	Weight (Kg/6.4m)	8808	1.2	2.8	<table border="1"> <thead> <tr> <th>Item No</th> <th>Thickness</th> <th>Weight (Kg/6.4m)</th> </tr> </thead> <tbody> <tr> <td>BYP-01</td> <td>1.2</td> <td>1.4</td> </tr> </tbody> </table>	Item No	Thickness	Weight (Kg/6.4m)	BYP-01	1.2	1.4	<table border="1"> <thead> <tr> <th>Item No</th> <th>Thickness</th> <th>Weight (Kg/6.4m)</th> </tr> </thead> <tbody> <tr> <td>01-031</td> <td>1.2</td> <td>1.7</td> </tr> </tbody> </table>	Item No	Thickness	Weight (Kg/6.4m)	01-031	1.2	1.7
Item No	Thickness	Weight (Kg/6.4m)																		
8808	1.2	2.8																		
Item No	Thickness	Weight (Kg/6.4m)																		
BYP-01	1.2	1.4																		
Item No	Thickness	Weight (Kg/6.4m)																		
01-031	1.2	1.7																		

80/88 SL IDING DOOR/WINDOW

<p>百叶片 LOOVER</p>	<p>纱窗料 NET</p>																			
<table border="1"> <thead> <tr> <th>Item No</th> <th>Thickness</th> <th>Weight (Kg/6.4m)</th> </tr> </thead> <tbody> <tr> <td>BYT-02</td> <td>1.1</td> <td>1.8</td> </tr> </tbody> </table>	Item No	Thickness	Weight (Kg/6.4m)	BYT-02	1.1	1.8	<table border="1"> <thead> <tr> <th>Item No</th> <th>Thickness</th> <th>Weight (Kg/6.4m)</th> </tr> </thead> <tbody> <tr> <td>01-032</td> <td>1.9</td> <td>3.6</td> </tr> </tbody> </table>	Item No	Thickness	Weight (Kg/6.4m)	01-032	1.9	3.6	<table border="1"> <thead> <tr> <th>Item No</th> <th>Thickness</th> <th>Weight (Kg/6.4m)</th> </tr> </thead> <tbody> <tr> <td></td> <td></td> <td></td> </tr> </tbody> </table>	Item No	Thickness	Weight (Kg/6.4m)			
Item No	Thickness	Weight (Kg/6.4m)																		
BYT-02	1.1	1.8																		
Item No	Thickness	Weight (Kg/6.4m)																		
01-032	1.9	3.6																		
Item No	Thickness	Weight (Kg/6.4m)																		
<table border="1"> <thead> <tr> <th>Item No</th> <th>Thickness</th> <th>Weight (Kg/6.4m)</th> </tr> </thead> <tbody> <tr> <td></td> <td></td> <td></td> </tr> </tbody> </table>	Item No	Thickness	Weight (Kg/6.4m)				<table border="1"> <thead> <tr> <th>Item No</th> <th>Thickness</th> <th>Weight (Kg/6.4m)</th> </tr> </thead> <tbody> <tr> <td></td> <td></td> <td></td> </tr> </tbody> </table>	Item No	Thickness	Weight (Kg/6.4m)				<table border="1"> <thead> <tr> <th>Item No</th> <th>Thickness</th> <th>Weight (Kg/6.4m)</th> </tr> </thead> <tbody> <tr> <td></td> <td></td> <td></td> </tr> </tbody> </table>	Item No	Thickness	Weight (Kg/6.4m)			
Item No	Thickness	Weight (Kg/6.4m)																		
Item No	Thickness	Weight (Kg/6.4m)																		
Item No	Thickness	Weight (Kg/6.4m)																		



2001 LUXURY SLIDING DOOR/WINDOW

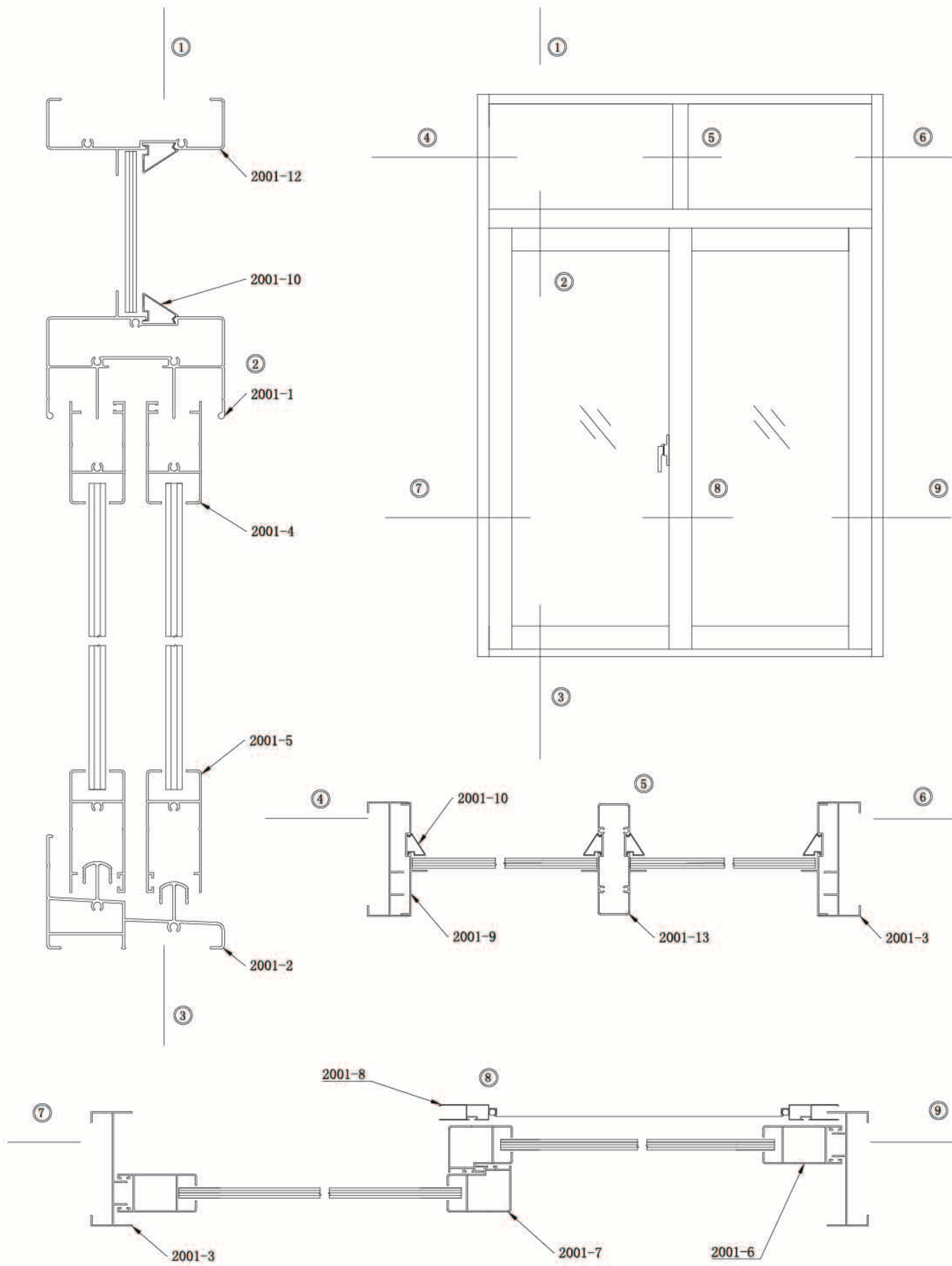

2001 LUXURY SLIDING DOOR/WINDOW

<p>固上滑 TOP SLIDING</p> <table border="1"> <thead> <tr> <th>Item No</th> <th>Thickness</th> <th>Weight (Kg/6.4m)</th> </tr> </thead> <tbody> <tr> <td rowspan="2">2001-1</td> <td>1.2</td> <td>8.2</td> </tr> <tr> <td>1.0</td> <td>7.1</td> </tr> </tbody> </table>	Item No	Thickness	Weight (Kg/6.4m)	2001-1	1.2	8.2	1.0	7.1	<p>高下滑 BOTTOM</p> <table border="1"> <thead> <tr> <th>Item No</th> <th>Thickness</th> <th>Weight (Kg/6.4m)</th> </tr> </thead> <tbody> <tr> <td rowspan="2">2001-2</td> <td>1.2</td> <td>7.1</td> </tr> <tr> <td>1.0</td> <td>6</td> </tr> </tbody> </table>	Item No	Thickness	Weight (Kg/6.4m)	2001-2	1.2	7.1	1.0	6	<p>平下滑 BOTTOM</p> <table border="1"> <thead> <tr> <th>Item No</th> <th>Thickness</th> <th>Weight (Kg/6.4m)</th> </tr> </thead> <tbody> <tr> <td>2001-2A</td> <td>1.2</td> <td>5.9</td> </tr> </tbody> </table>	Item No	Thickness	Weight (Kg/6.4m)	2001-2A	1.2	5.9		
Item No	Thickness	Weight (Kg/6.4m)																								
2001-1	1.2	8.2																								
	1.0	7.1																								
Item No	Thickness	Weight (Kg/6.4m)																								
2001-2	1.2	7.1																								
	1.0	6																								
Item No	Thickness	Weight (Kg/6.4m)																								
2001-2A	1.2	5.9																								
<p>边封 SIDE-VERTICAL</p> <table border="1"> <thead> <tr> <th>Item No</th> <th>Thickness</th> <th>Weight (Kg/6.4m)</th> </tr> </thead> <tbody> <tr> <td rowspan="2">2001-3</td> <td>1.2</td> <td>4</td> </tr> <tr> <td>1.0</td> <td>3.8</td> </tr> </tbody> </table>	Item No	Thickness	Weight (Kg/6.4m)	2001-3	1.2	4	1.0	3.8	<p>上方 TOP-SHUTTER</p> <table border="1"> <thead> <tr> <th>Item No</th> <th>Thickness</th> <th>Weight (Kg/6.4m)</th> </tr> </thead> <tbody> <tr> <td rowspan="2">2001-4</td> <td>1.2</td> <td>3.5</td> </tr> <tr> <td>1.0</td> <td>3</td> </tr> </tbody> </table>	Item No	Thickness	Weight (Kg/6.4m)	2001-4	1.2	3.5	1.0	3	<p>下方 BOTTOM-SHUTTER</p> <table border="1"> <thead> <tr> <th>Item No</th> <th>Thickness</th> <th>Weight (Kg/6.4m)</th> </tr> </thead> <tbody> <tr> <td rowspan="2">2001-5</td> <td>1.2</td> <td>3.8</td> </tr> <tr> <td>1.0</td> <td>3.1</td> </tr> </tbody> </table>	Item No	Thickness	Weight (Kg/6.4m)	2001-5	1.2	3.8	1.0	3.1
Item No	Thickness	Weight (Kg/6.4m)																								
2001-3	1.2	4																								
	1.0	3.8																								
Item No	Thickness	Weight (Kg/6.4m)																								
2001-4	1.2	3.5																								
	1.0	3																								
Item No	Thickness	Weight (Kg/6.4m)																								
2001-5	1.2	3.8																								
	1.0	3.1																								
<p>光企 LOCKING</p> <table border="1"> <thead> <tr> <th>Item No</th> <th>Thickness</th> <th>Weight (Kg/6.4m)</th> </tr> </thead> <tbody> <tr> <td rowspan="2">2001-6</td> <td>1.2</td> <td>4.5</td> </tr> <tr> <td>1.0</td> <td>3.7</td> </tr> </tbody> </table>	Item No	Thickness	Weight (Kg/6.4m)	2001-6	1.2	4.5	1.0	3.7	<p>压线 ADAPTOR</p> <table border="1"> <thead> <tr> <th>Item No</th> <th>Thickness</th> <th>Weight (Kg/6.4m)</th> </tr> </thead> <tbody> <tr> <td>2001-16</td> <td>1.0</td> <td>0.53</td> </tr> </tbody> </table>	Item No	Thickness	Weight (Kg/6.4m)	2001-16	1.0	0.53	<p>勾企 INTERLOCK</p> <table border="1"> <thead> <tr> <th>Item No</th> <th>Thickness</th> <th>Weight (Kg/6.4m)</th> </tr> </thead> <tbody> <tr> <td rowspan="2">2001-7</td> <td>1.2</td> <td>4.1</td> </tr> <tr> <td>1.0</td> <td>3.5</td> </tr> </tbody> </table>	Item No	Thickness	Weight (Kg/6.4m)	2001-7	1.2	4.1	1.0	3.5		
Item No	Thickness	Weight (Kg/6.4m)																								
2001-6	1.2	4.5																								
	1.0	3.7																								
Item No	Thickness	Weight (Kg/6.4m)																								
2001-16	1.0	0.53																								
Item No	Thickness	Weight (Kg/6.4m)																								
2001-7	1.2	4.1																								
	1.0	3.5																								
<p>纱窗料 NET</p> <table border="1"> <thead> <tr> <th>Item No</th> <th>Thickness</th> <th>Weight (Kg/6.4m)</th> </tr> </thead> <tbody> <tr> <td>2001-8</td> <td>1.1</td> <td>2.3</td> </tr> </tbody> </table>	Item No	Thickness	Weight (Kg/6.4m)	2001-8	1.1	2.3	<p>插板 SIDE-COVER</p> <table border="1"> <thead> <tr> <th>Item No</th> <th>Thickness</th> <th>Weight (Kg/6.4m)</th> </tr> </thead> <tbody> <tr> <td>2001-9</td> <td>1.0</td> <td>2.3</td> </tr> </tbody> </table>	Item No	Thickness	Weight (Kg/6.4m)	2001-9	1.0	2.3	<p>压线 BEADING</p> <table border="1"> <thead> <tr> <th>Item No</th> <th>Thickness</th> <th>Weight (Kg/6.4m)</th> </tr> </thead> <tbody> <tr> <td>2001-10</td> <td>0.8</td> <td>0.6</td> </tr> </tbody> </table>	Item No	Thickness	Weight (Kg/6.4m)	2001-10	0.8	0.6						
Item No	Thickness	Weight (Kg/6.4m)																								
2001-8	1.1	2.3																								
Item No	Thickness	Weight (Kg/6.4m)																								
2001-9	1.0	2.3																								
Item No	Thickness	Weight (Kg/6.4m)																								
2001-10	0.8	0.6																								
<p>上滑 TOP-SLIDING</p> <table border="1"> <thead> <tr> <th>Item No</th> <th>Thickness</th> <th>Weight (Kg/6.4m)</th> </tr> </thead> <tbody> <tr> <td rowspan="2">2001-11</td> <td>1.2</td> <td>5.4</td> </tr> <tr> <td>1.0</td> <td>4.7</td> </tr> </tbody> </table>	Item No	Thickness	Weight (Kg/6.4m)	2001-11	1.2	5.4	1.0	4.7	<p>上窗 TOP-VENT</p> <table border="1"> <thead> <tr> <th>Item No</th> <th>Thickness</th> <th>Weight (Kg/6.4m)</th> </tr> </thead> <tbody> <tr> <td>2001-12</td> <td>1.2</td> <td>3.6</td> </tr> </tbody> </table>	Item No	Thickness	Weight (Kg/6.4m)	2001-12	1.2	3.6	<p>中柱 VENT-TRANSOME</p> <table border="1"> <thead> <tr> <th>Item No</th> <th>Thickness</th> <th>Weight (Kg/6.4m)</th> </tr> </thead> <tbody> <tr> <td>2001-13</td> <td>1.2</td> <td>5.2</td> </tr> </tbody> </table>	Item No	Thickness	Weight (Kg/6.4m)	2001-13	1.2	5.2				
Item No	Thickness	Weight (Kg/6.4m)																								
2001-11	1.2	5.4																								
	1.0	4.7																								
Item No	Thickness	Weight (Kg/6.4m)																								
2001-12	1.2	3.6																								
Item No	Thickness	Weight (Kg/6.4m)																								
2001-13	1.2	5.2																								

* Weight Tolerance of +/- 5% applicable.

2001 LUXURY SLIDING DOOR/WINDOW

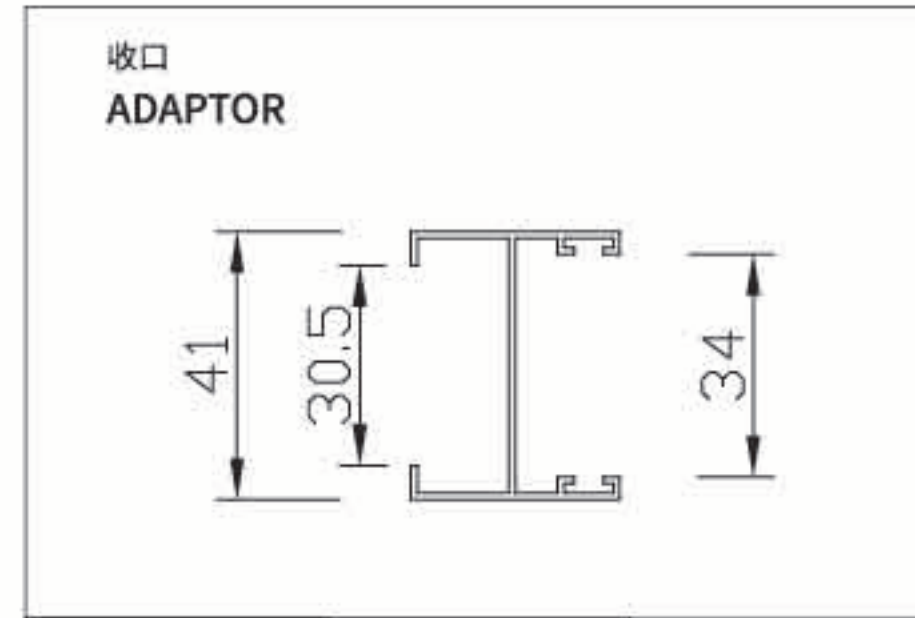

Item No	Thickness	Weight (Kg/6.4m)
2001-14	1.2	2.2

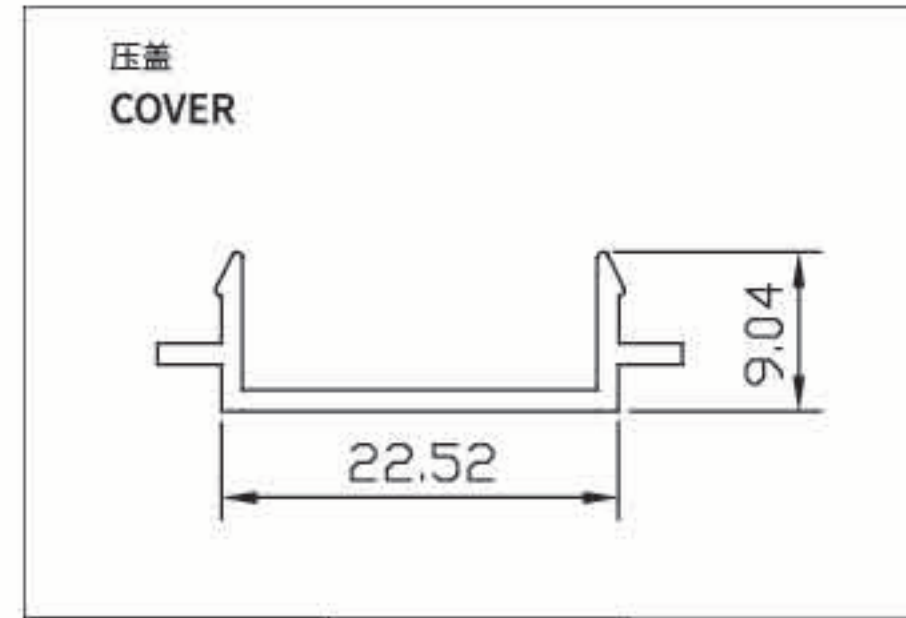

Item No	Thickness	Weight (Kg/6.4m)
2001-15	1.2	1.1

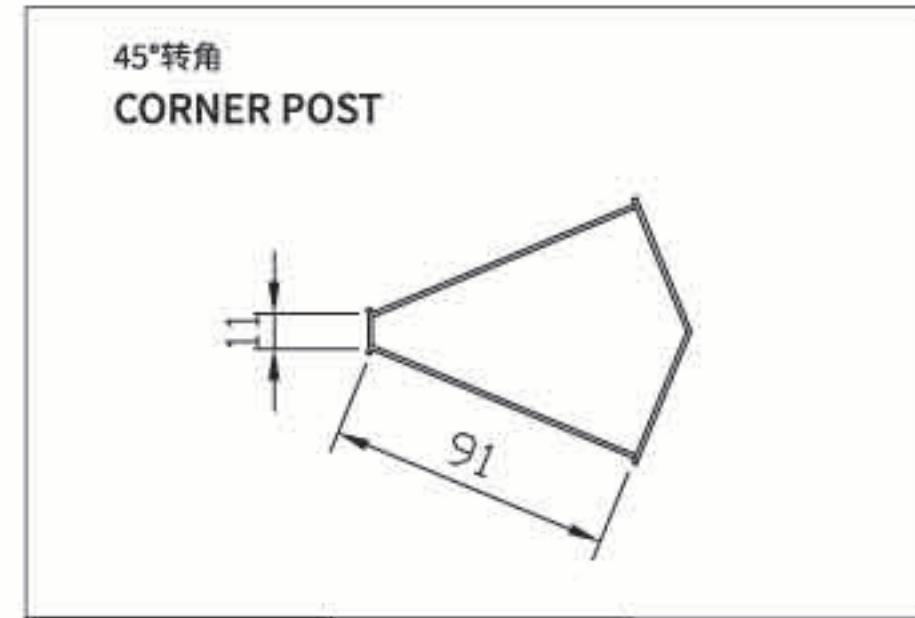

Item No	Thickness	Weight (Kg/6.4m)
2001-17	1.35	7

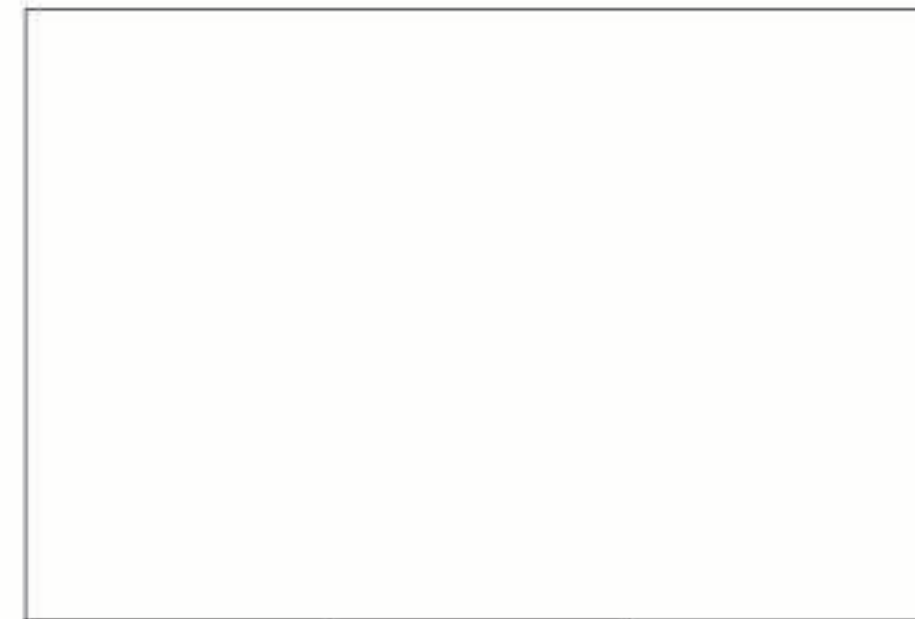

Item No	Thickness	Weight (Kg/6.4m)



Item No	Thickness	Weight (Kg/6.4m)

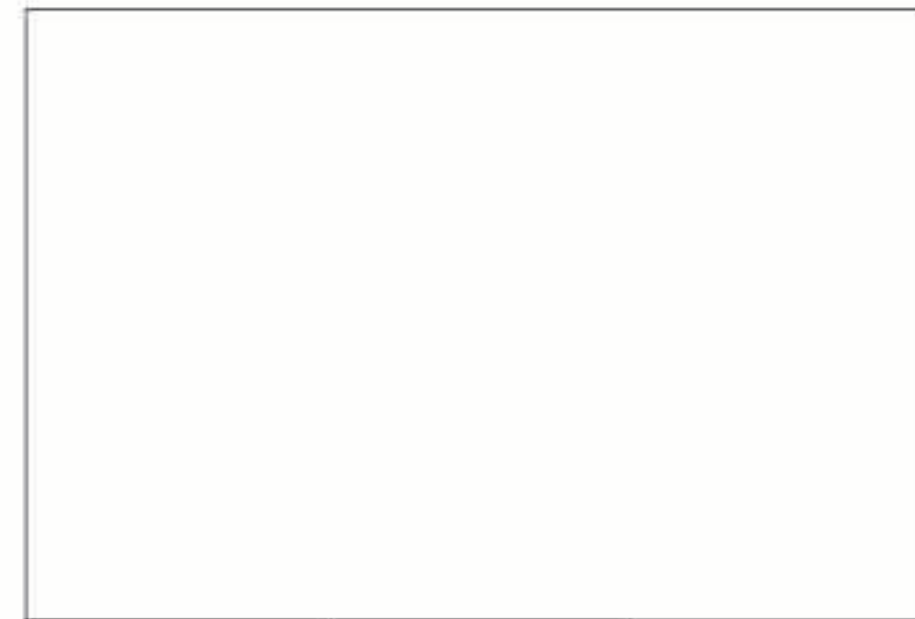

Item No	Thickness	Weight (Kg/6.4m)

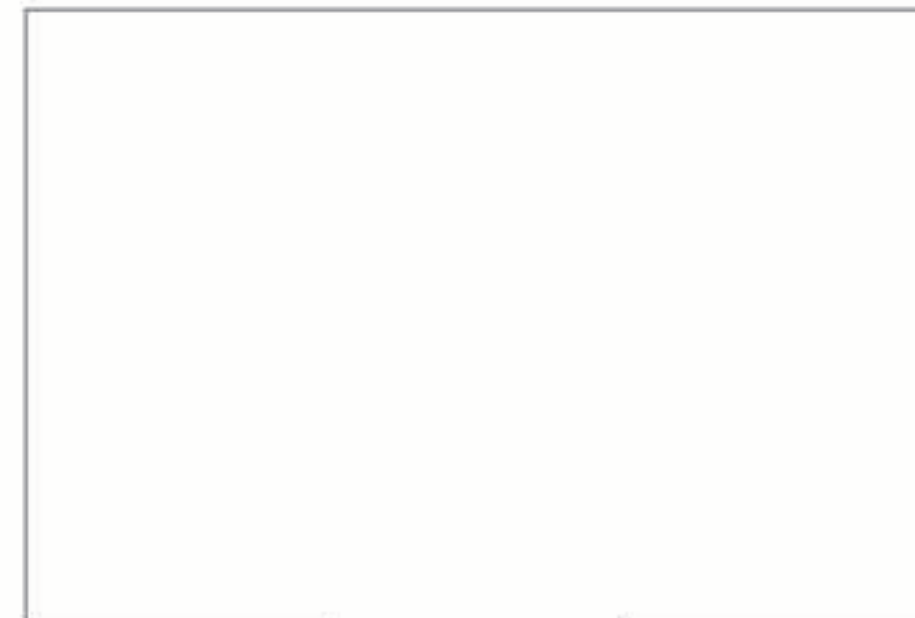

Item No	Thickness	Weight (Kg/6.4m)

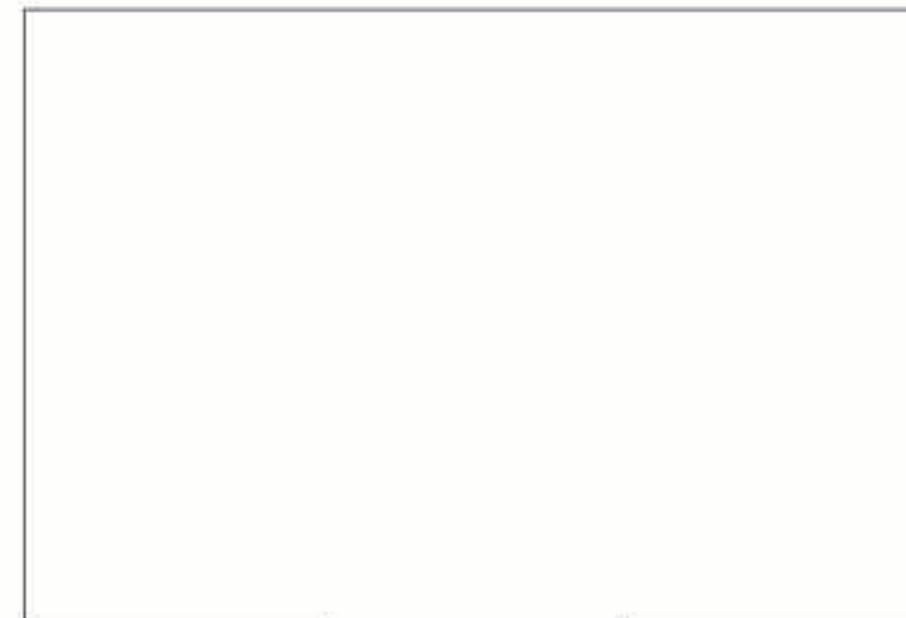

Item No	Thickness	Weight (Kg/6.4m)

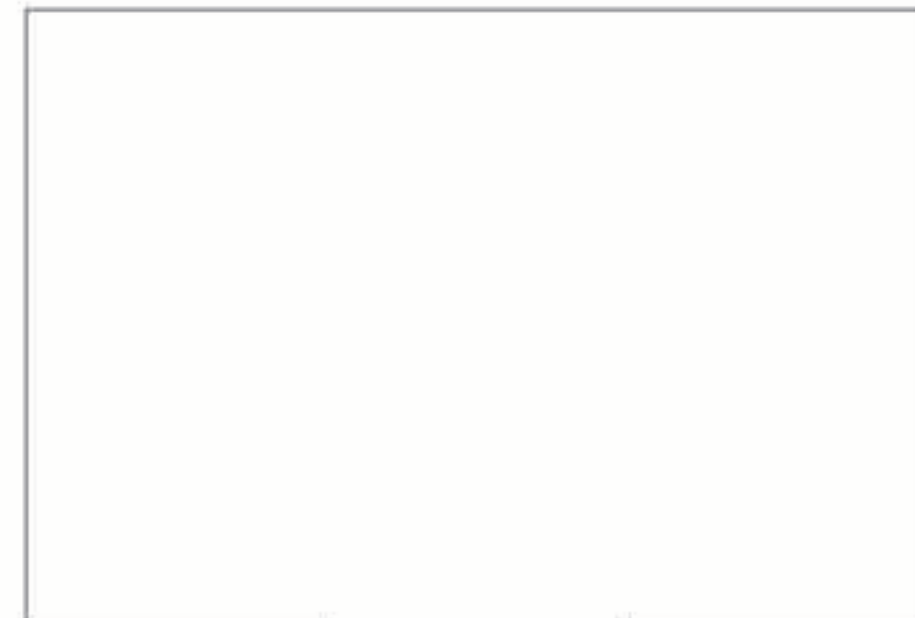

Item No	Thickness	Weight (Kg/6.4m)



Item No	Thickness	Weight (Kg/6.4m)



Item No	Thickness	Weight (Kg/6.4m)



Item No	Thickness	Weight (Kg/6.4m)

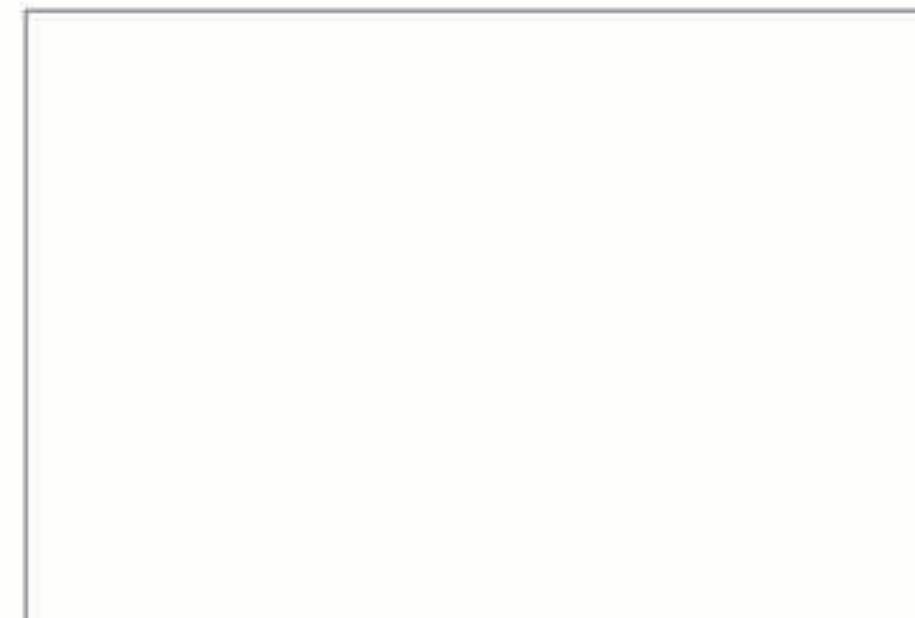

Item No	Thickness	Weight (Kg/6.4m)

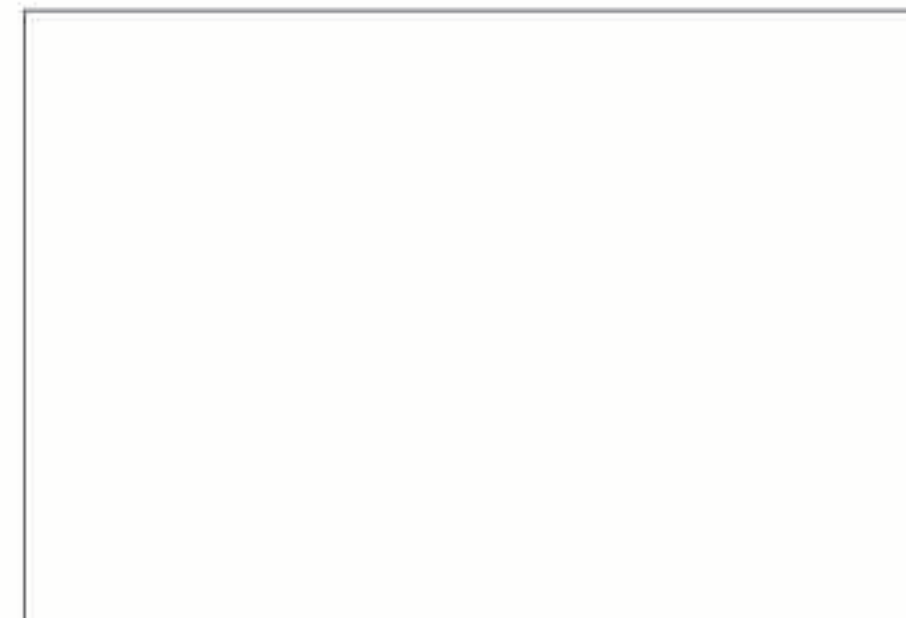

Item No	Thickness	Weight (Kg/6.4m)

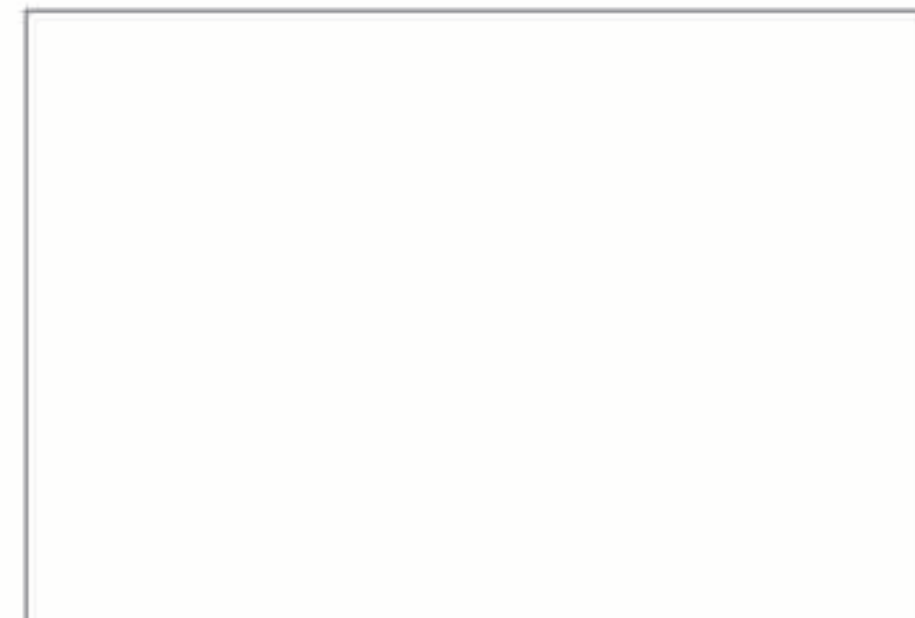

Item No	Thickness	Weight (Kg/6.4m)



GT90 SLIDING DOOR/WINDOW SERIES

TWO RAIL/TAREE RAIL SLIDING DOOR SERIES

双玻扇料
SHUTTER

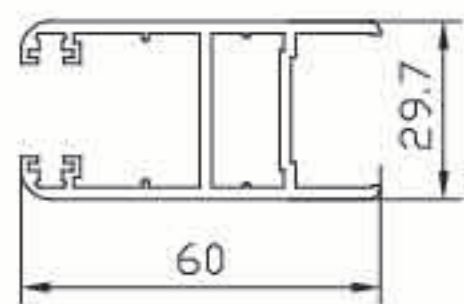

Item No	Thickness	Weight (Kg/6.4m)
GT90-14B	2	6.9

扇料
SHUTTER

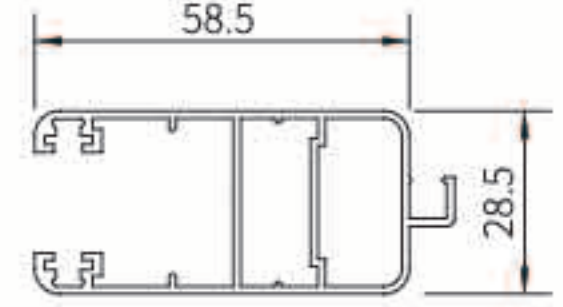

Item No	Thickness	Weight (Kg/6.4m)
GT90-02B	1.2	5.5

勾板
INJER LOCK

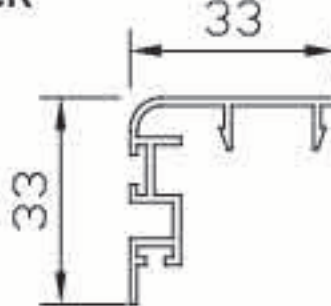

Item No	Thickness	Weight (Kg/6.4m)
GT90-04	1.0	2.0
GT90-04A	1.2	2.3
	1.5	2.5

勾板
INJER LOCK

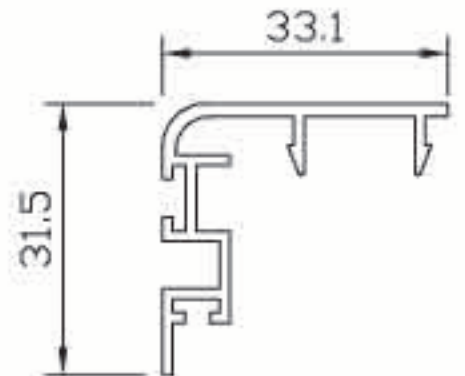

Item No	Thickness	Weight (Kg/6.4m)
GT90-04B	1.5	2.7

纱扇压条
MOSQUITO-NET

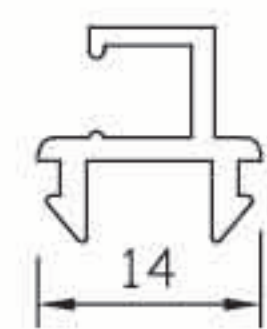

Item No	Thickness	Weight (Kg/6.4m)
GT90-05	1.5	1.1

边框压条
DOURLE GLAZING BEADING

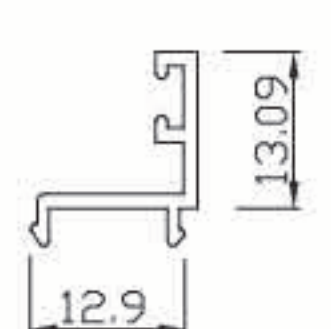

Item No	Thickness	Weight (Kg/6.4m)
GT90-19	1.2	0.8

收口
MEETING CHINNEL

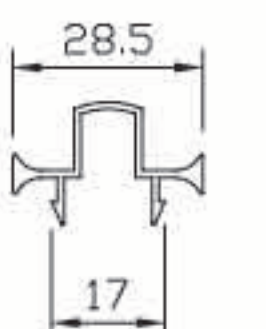

Item No	Thickness	Weight (Kg/6.4m)
GT90-06	1.2	1.5

压线
BEADING

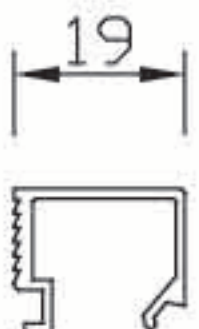

Item No	Thickness	Weight (Kg/6.4m)
01-142	1.0	1.1

三轨框料
3-TRACK SLIDING

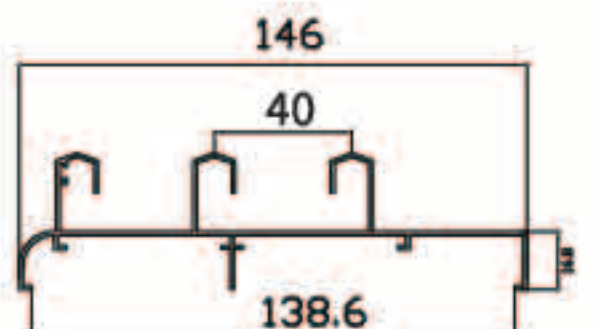

Item No	Thickness	Weight (Kg/6.4m)
GT90-23	1.25	6.99

边框
NET SHUTTER/TRANSOME

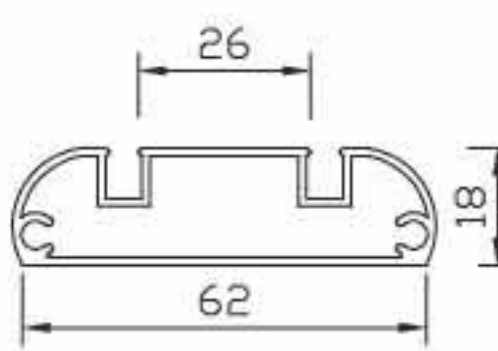

Item No	Thickness	Weight (Kg/6.4m)
GT90-15	1.2	4.3

扇料角码
EURO ANGLE

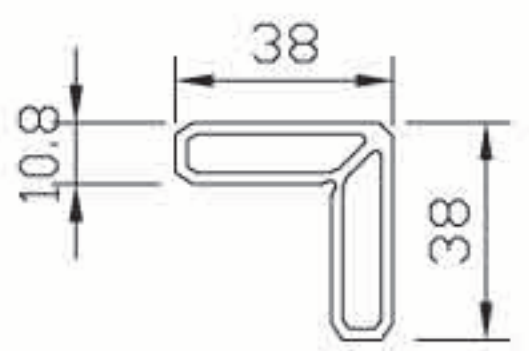

Item No	Thickness	Weight (Kg/6.4m)
GT90-17	2	5

二轨纱窗料
NET

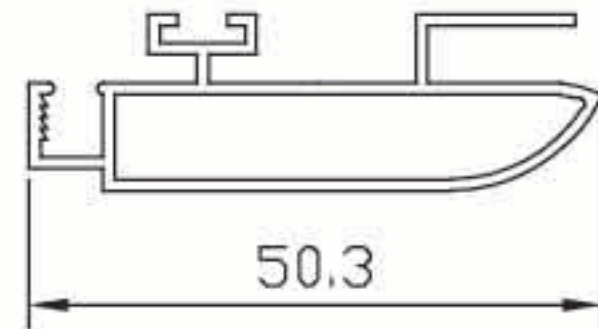

Item No	Thickness	Weight (Kg/6.4m)
GT90-12	1.0	2.7

扇中柱
TRANSOME

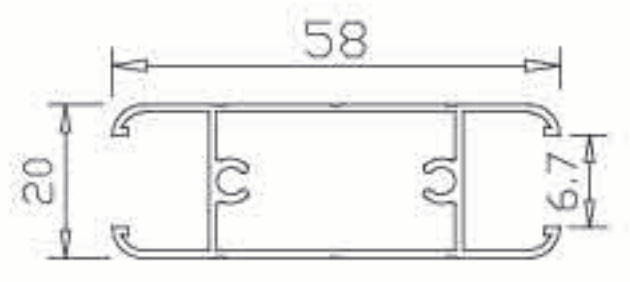

Item No	Thickness	Weight (Kg/6.4m)
GT90-03	1.2	3.8

二轨边固
VENT (01-142) (2001-10)

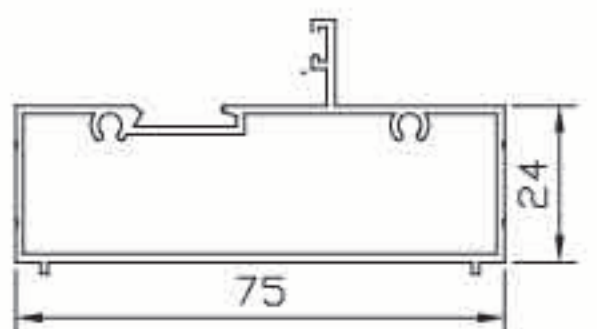

Item No	Thickness	Weight (Kg/6.4m)
GT90-10	1.2	5.3

二轨框料
2-TRACK

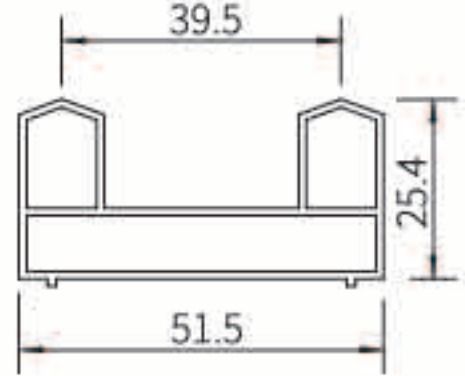

Item No	Thickness	Weight (Kg/6.4m)
GT90-22	1.1	3.7

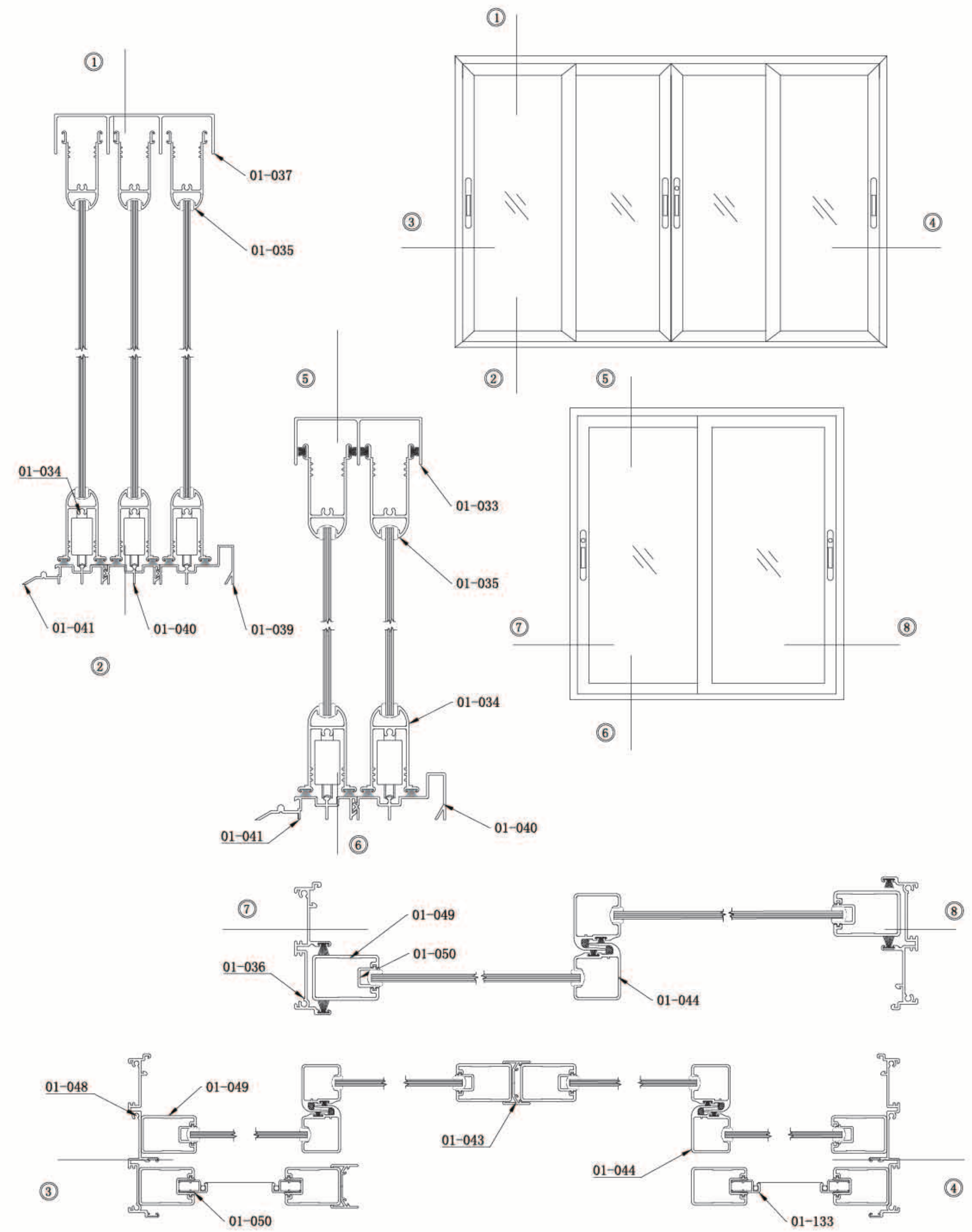

* Weight Tolerance of +/- 5% applicable.

TWO RAIL/TAREE RAIL SLIDING DOOR SERIES

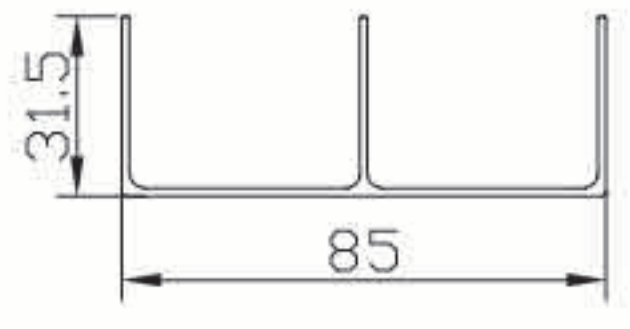
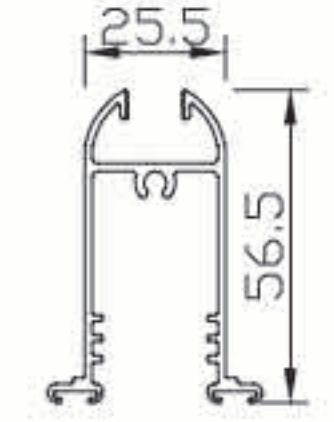
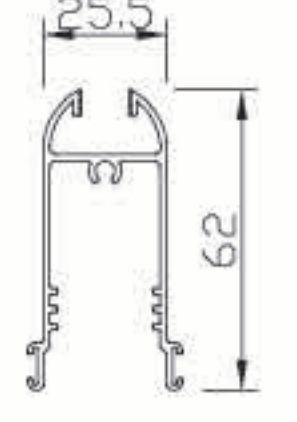
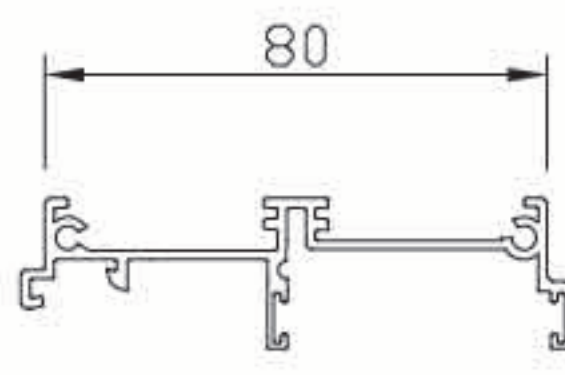
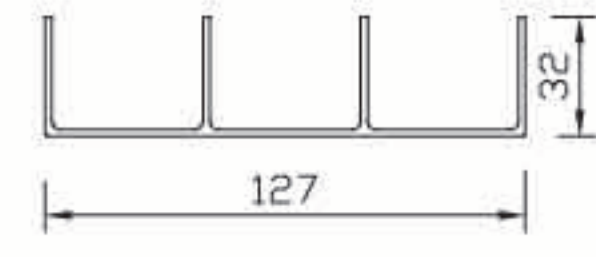
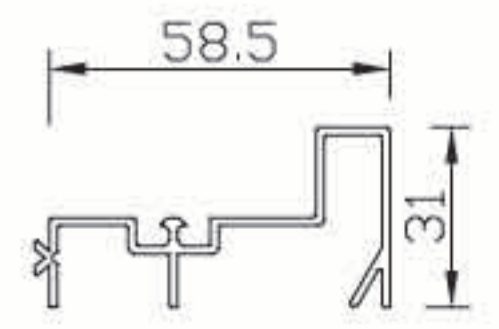
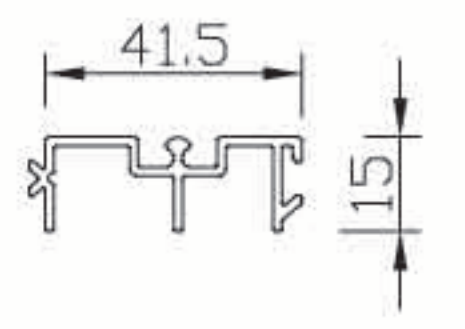
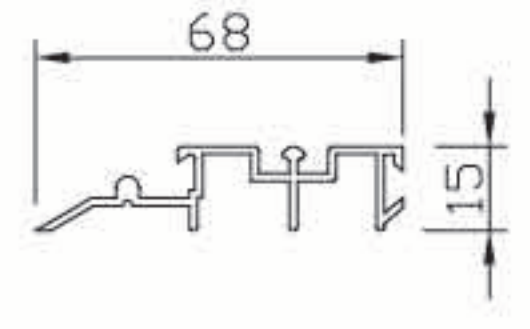
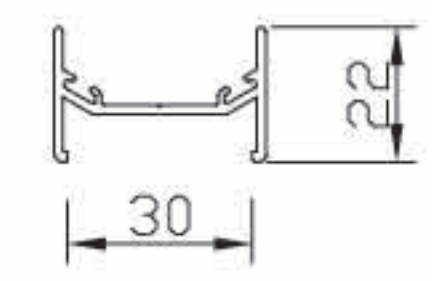
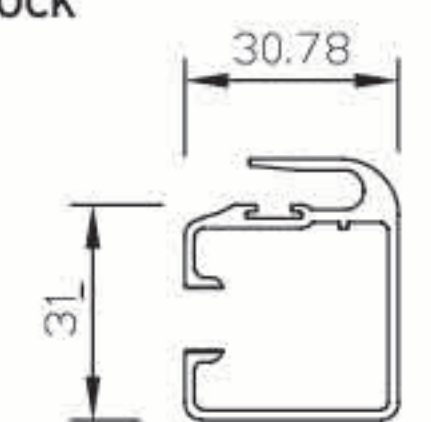
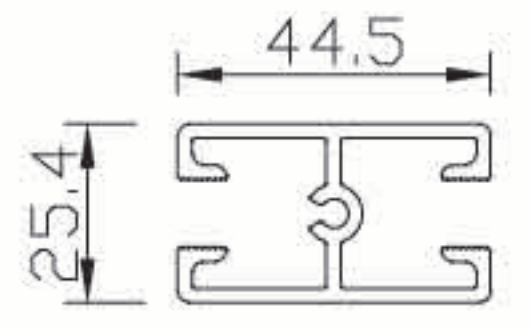
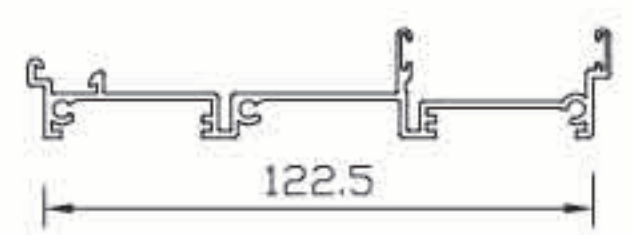
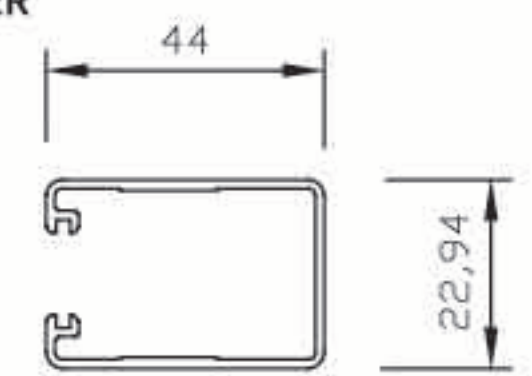
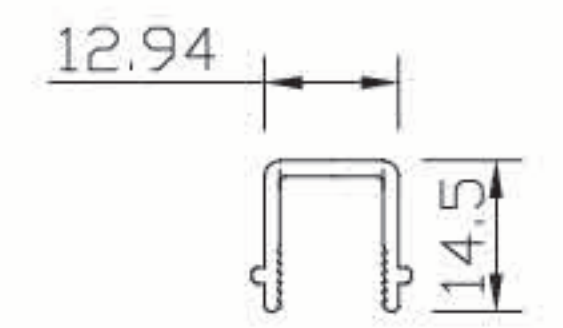
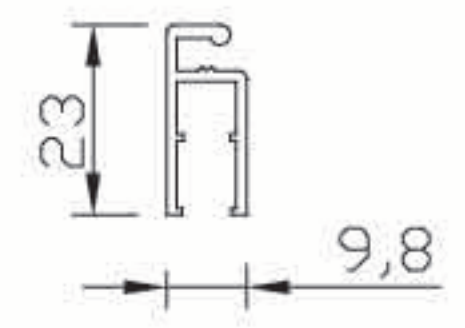

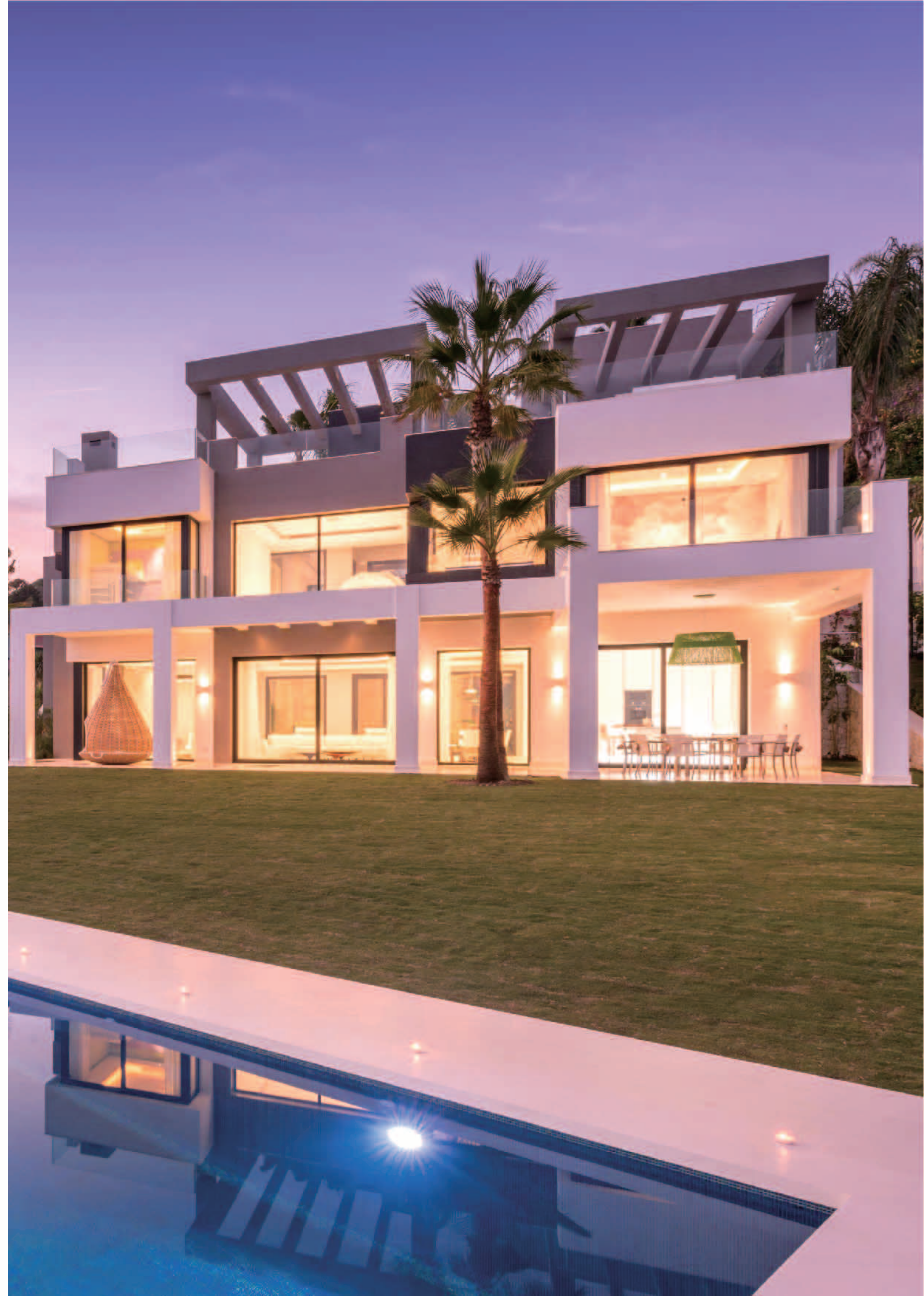



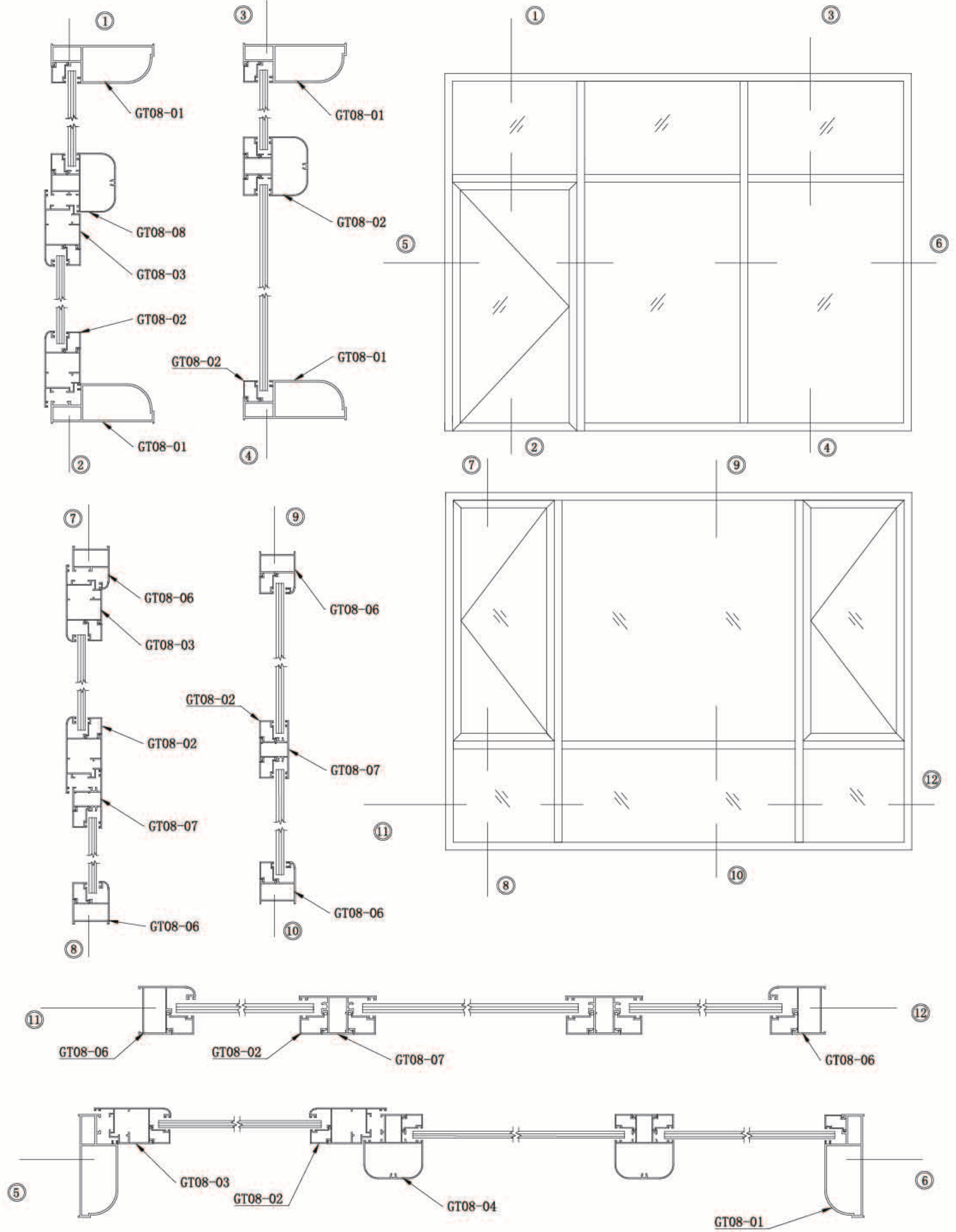

<p>二轨上滑 2-TRACK TOP SLIDING</p> 	<p>下方 BOTTOM SHUTTER</p> 	<p>上方 TOP-SHUTTER</p> 																		
<table border="1"> <thead> <tr> <th>Item No</th> <th>Thickness</th> <th>Weight (Kg/6.4m)</th> </tr> </thead> <tbody> <tr> <td>01-033</td> <td>1.45</td> <td>4.5</td> </tr> </tbody> </table>	Item No	Thickness	Weight (Kg/6.4m)	01-033	1.45	4.5	<table border="1"> <thead> <tr> <th>Item No</th> <th>Thickness</th> <th>Weight (Kg/6.4m)</th> </tr> </thead> <tbody> <tr> <td>01-034</td> <td>1.35</td> <td>4.6</td> </tr> </tbody> </table>	Item No	Thickness	Weight (Kg/6.4m)	01-034	1.35	4.6	<table border="1"> <thead> <tr> <th>Item No</th> <th>Thickness</th> <th>Weight (Kg/6.4m)</th> </tr> </thead> <tbody> <tr> <td>01-035</td> <td>1.35</td> <td>4.7</td> </tr> </tbody> </table>	Item No	Thickness	Weight (Kg/6.4m)	01-035	1.35	4.7
Item No	Thickness	Weight (Kg/6.4m)																		
01-033	1.45	4.5																		
Item No	Thickness	Weight (Kg/6.4m)																		
01-034	1.35	4.6																		
Item No	Thickness	Weight (Kg/6.4m)																		
01-035	1.35	4.7																		
<p>二轨边框 2-TRACK FRAME</p> 	<p>三轨上滑 3-TRACK TOP SLIDING</p> 	<p>下轨A料 BOTTOM</p> 																		
<table border="1"> <thead> <tr> <th>Item No</th> <th>Thickness</th> <th>Weight (Kg/6.4m)</th> </tr> </thead> <tbody> <tr> <td>01-036</td> <td>1.45</td> <td>5.2</td> </tr> </tbody> </table>	Item No	Thickness	Weight (Kg/6.4m)	01-036	1.45	5.2	<table border="1"> <thead> <tr> <th>Item No</th> <th>Thickness</th> <th>Weight (Kg/6.4m)</th> </tr> </thead> <tbody> <tr> <td>01-037</td> <td>1.8</td> <td>8.1</td> </tr> </tbody> </table>	Item No	Thickness	Weight (Kg/6.4m)	01-037	1.8	8.1	<table border="1"> <thead> <tr> <th>Item No</th> <th>Thickness</th> <th>Weight (Kg/6.4m)</th> </tr> </thead> <tbody> <tr> <td>01-039</td> <td>1.4</td> <td>4.1</td> </tr> </tbody> </table>	Item No	Thickness	Weight (Kg/6.4m)	01-039	1.4	4.1
Item No	Thickness	Weight (Kg/6.4m)																		
01-036	1.45	5.2																		
Item No	Thickness	Weight (Kg/6.4m)																		
01-037	1.8	8.1																		
Item No	Thickness	Weight (Kg/6.4m)																		
01-039	1.4	4.1																		
<p>下轨B料 BOTTOM</p> 	<p>下轨C料 BEADING</p> 	<p>收口 ADAPTOR</p> 																		
<table border="1"> <thead> <tr> <th>Item No</th> <th>Thickness</th> <th>Weight (Kg/6.4m)</th> </tr> </thead> <tbody> <tr> <td>01-040</td> <td>1.4</td> <td>2.7</td> </tr> </tbody> </table>	Item No	Thickness	Weight (Kg/6.4m)	01-040	1.4	2.7	<table border="1"> <thead> <tr> <th>Item No</th> <th>Thickness</th> <th>Weight (Kg/6.4m)</th> </tr> </thead> <tbody> <tr> <td>01-141</td> <td>1.45</td> <td>3.7</td> </tr> </tbody> </table>	Item No	Thickness	Weight (Kg/6.4m)	01-141	1.45	3.7	<table border="1"> <thead> <tr> <th>Item No</th> <th>Thickness</th> <th>Weight (Kg/6.4m)</th> </tr> </thead> <tbody> <tr> <td>01-043</td> <td>1.5</td> <td>2.3</td> </tr> </tbody> </table>	Item No	Thickness	Weight (Kg/6.4m)	01-043	1.5	2.3
Item No	Thickness	Weight (Kg/6.4m)																		
01-040	1.4	2.7																		
Item No	Thickness	Weight (Kg/6.4m)																		
01-141	1.45	3.7																		
Item No	Thickness	Weight (Kg/6.4m)																		
01-043	1.5	2.3																		
<p>勾企 INTER LOCK</p> 	<p>中横 TRANSOME</p> 	<p>三轨边框 3-TRACK FRAME</p> 																		
<table border="1"> <thead> <tr> <th>Item No</th> <th>Thickness</th> <th>Weight (Kg/6.4m)</th> </tr> </thead> <tbody> <tr> <td>01-044</td> <td>1.45</td> <td>4.1</td> </tr> </tbody> </table>	Item No	Thickness	Weight (Kg/6.4m)	01-044	1.45	4.1	<table border="1"> <thead> <tr> <th>Item No</th> <th>Thickness</th> <th>Weight (Kg/6.4m)</th> </tr> </thead> <tbody> <tr> <td>01-046</td> <td>2</td> <td>5.8</td> </tr> </tbody> </table>	Item No	Thickness	Weight (Kg/6.4m)	01-046	2	5.8	<table border="1"> <thead> <tr> <th>Item No</th> <th>Thickness</th> <th>Weight (Kg/6.4m)</th> </tr> </thead> <tbody> <tr> <td>01-048</td> <td>1.5</td> <td>7.1</td> </tr> </tbody> </table>	Item No	Thickness	Weight (Kg/6.4m)	01-048	1.5	7.1
Item No	Thickness	Weight (Kg/6.4m)																		
01-044	1.45	4.1																		
Item No	Thickness	Weight (Kg/6.4m)																		
01-046	2	5.8																		
Item No	Thickness	Weight (Kg/6.4m)																		
01-048	1.5	7.1																		
<p>光企 SHUTTER</p> 	<p>压线 GLAZING CHANNEL</p> 	<p>纱窗料 NEL</p> 																		
<table border="1"> <thead> <tr> <th>Item No</th> <th>Thickness</th> <th>Weight (Kg/6.4m)</th> </tr> </thead> <tbody> <tr> <td>01-049</td> <td>1.4</td> <td>3.7</td> </tr> </tbody> </table>	Item No	Thickness	Weight (Kg/6.4m)	01-049	1.4	3.7	<table border="1"> <thead> <tr> <th>Item No</th> <th>Thickness</th> <th>Weight (Kg/6.4m)</th> </tr> </thead> <tbody> <tr> <td>01-050</td> <td>1.5</td> <td>1.1</td> </tr> </tbody> </table>	Item No	Thickness	Weight (Kg/6.4m)	01-050	1.5	1.1	<table border="1"> <thead> <tr> <th>Item No</th> <th>Thickness</th> <th>Weight (Kg/6.4m)</th> </tr> </thead> <tbody> <tr> <td>01-133</td> <td>1.3</td> <td>1.4</td> </tr> </tbody> </table>	Item No	Thickness	Weight (Kg/6.4m)	01-133	1.3	1.4
Item No	Thickness	Weight (Kg/6.4m)																		
01-049	1.4	3.7																		
Item No	Thickness	Weight (Kg/6.4m)																		
01-050	1.5	1.1																		
Item No	Thickness	Weight (Kg/6.4m)																		
01-133	1.3	1.4																		

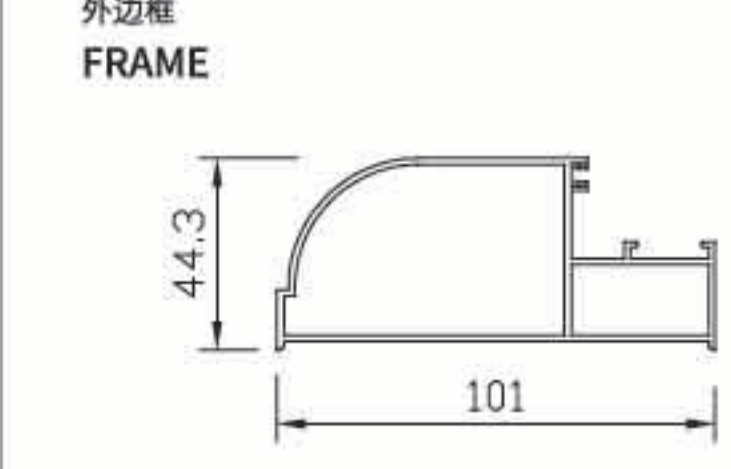

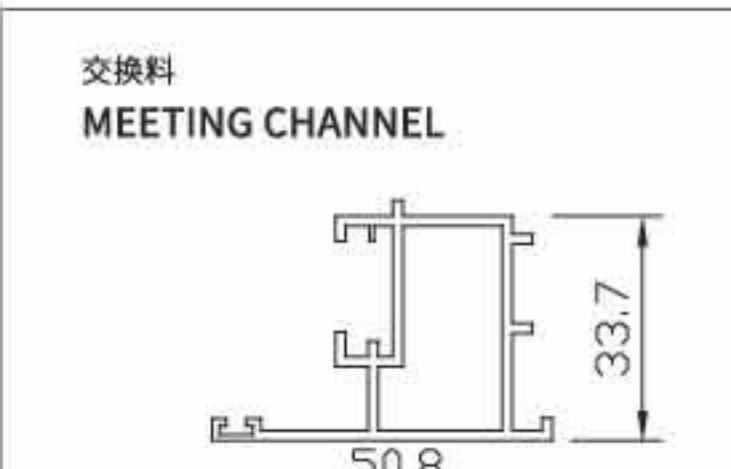
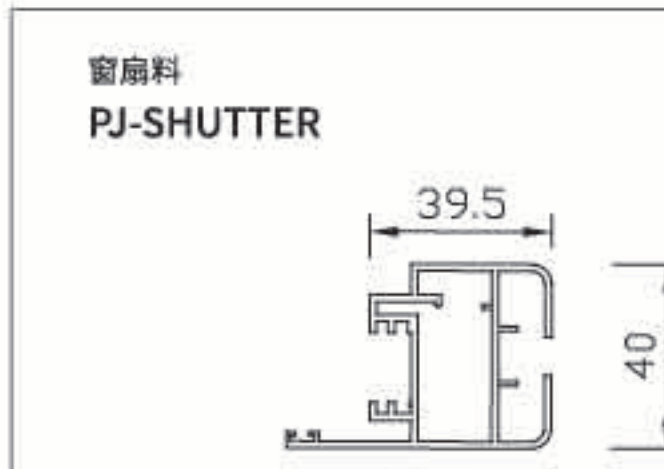
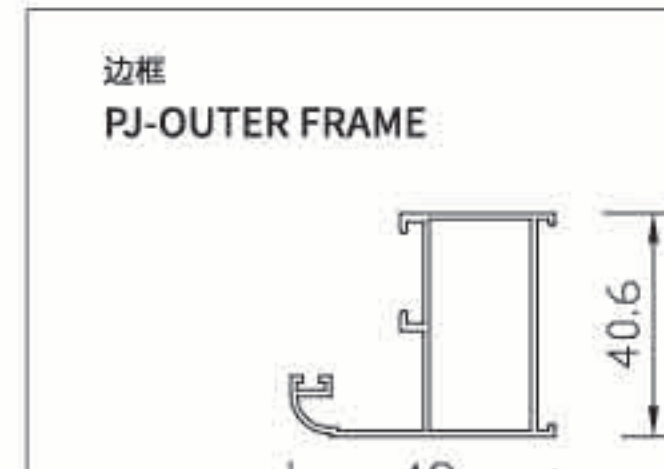
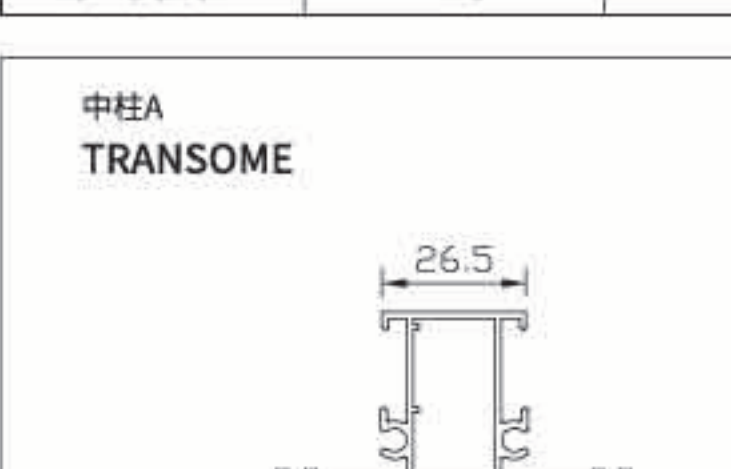
GT08 SERIES

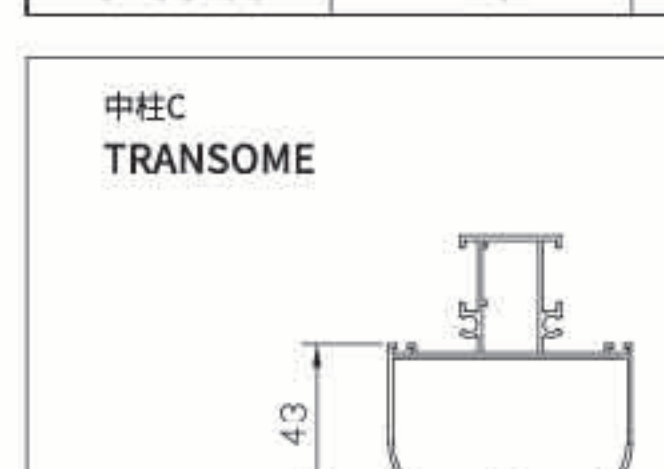
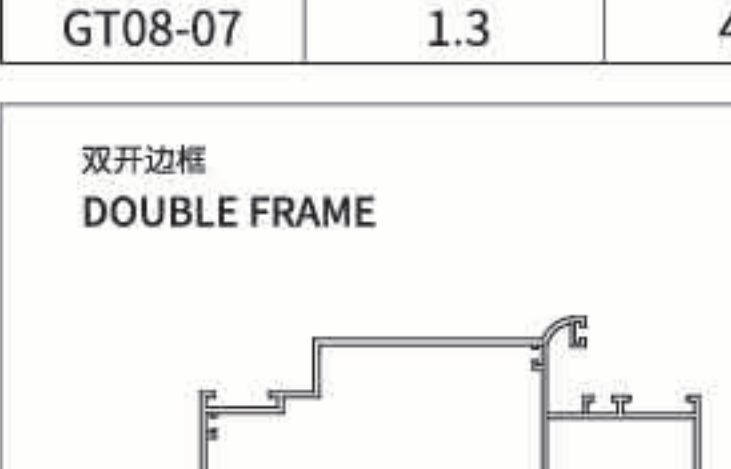
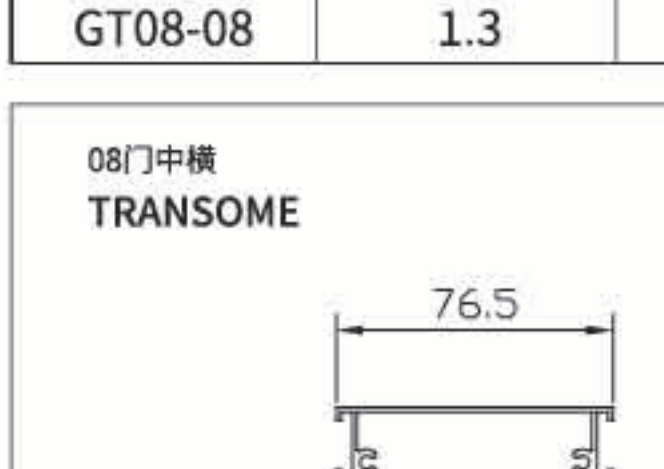

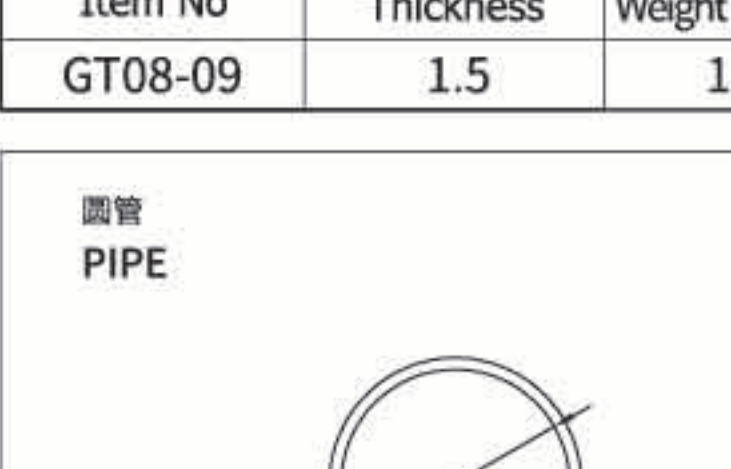
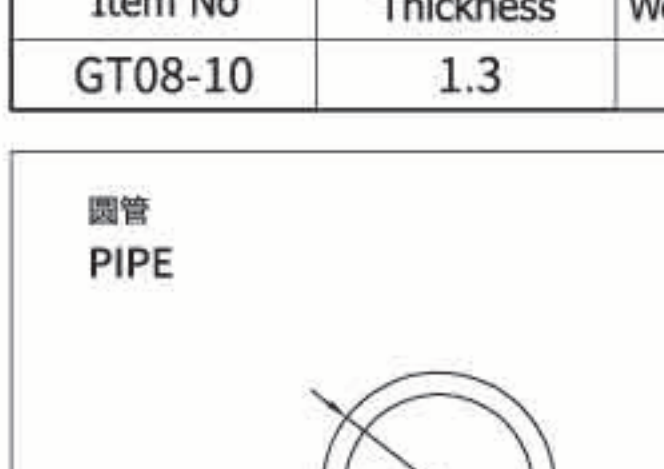
GT08 SERIES

<p>外边框 FRAME</p>  <table border="1"> <thead> <tr> <th>Item No</th> <th>Thickness</th> <th>Weight (Kg/6.4m)</th> </tr> </thead> <tbody> <tr> <td rowspan="2">GT08-01</td> <td>1.5</td> <td>8.3</td> </tr> <tr> <td>2.0</td> <td>11</td> </tr> </tbody> </table>	Item No	Thickness	Weight (Kg/6.4m)	GT08-01	1.5	8.3	2.0	11	<p>压线 BEADING</p>  <table border="1"> <thead> <tr> <th>Item No</th> <th>Thickness</th> <th>Weight (Kg/6.4m)</th> </tr> </thead> <tbody> <tr> <td>GT08-02</td> <td>1.2</td> <td>1.4</td> </tr> </tbody> </table>	Item No	Thickness	Weight (Kg/6.4m)	GT08-02	1.2	1.4	<p>门扇料 DOOR SHUTTER/OUT</p>  <table border="1"> <thead> <tr> <th>Item No</th> <th>Thickness</th> <th>Weight (Kg/6.4m)</th> </tr> </thead> <tbody> <tr> <td rowspan="2">GT08-03</td> <td>1.3</td> <td>5.8</td> </tr> <tr> <td>1.5</td> <td>6.9</td> </tr> </tbody> </table>	Item No	Thickness	Weight (Kg/6.4m)	GT08-03	1.3	5.8	1.5	6.9
Item No	Thickness	Weight (Kg/6.4m)																						
GT08-01	1.5	8.3																						
	2.0	11																						
Item No	Thickness	Weight (Kg/6.4m)																						
GT08-02	1.2	1.4																						
Item No	Thickness	Weight (Kg/6.4m)																						
GT08-03	1.3	5.8																						
	1.5	6.9																						
<p>交换料 MEETING CHANNEL</p>  <table border="1"> <thead> <tr> <th>Item No</th> <th>Thickness</th> <th>Weight (Kg/6.4m)</th> </tr> </thead> <tbody> <tr> <td>GT08-04</td> <td>1.5</td> <td>4.7</td> </tr> </tbody> </table>	Item No	Thickness	Weight (Kg/6.4m)	GT08-04	1.5	4.7	<p>窗扇料 PJ-SHUTTER</p>  <table border="1"> <thead> <tr> <th>Item No</th> <th>Thickness</th> <th>Weight (Kg/6.4m)</th> </tr> </thead> <tbody> <tr> <td>GT08-05</td> <td>1.5</td> <td>6.3</td> </tr> </tbody> </table>	Item No	Thickness	Weight (Kg/6.4m)	GT08-05	1.5	6.3	<p>边框 PJ-OUTER FRAME</p>  <table border="1"> <thead> <tr> <th>Item No</th> <th>Thickness</th> <th>Weight (Kg/6.4m)</th> </tr> </thead> <tbody> <tr> <td>GT08-06</td> <td>1.3</td> <td>3.9</td> </tr> </tbody> </table>	Item No	Thickness	Weight (Kg/6.4m)	GT08-06	1.3	3.9				
Item No	Thickness	Weight (Kg/6.4m)																						
GT08-04	1.5	4.7																						
Item No	Thickness	Weight (Kg/6.4m)																						
GT08-05	1.5	6.3																						
Item No	Thickness	Weight (Kg/6.4m)																						
GT08-06	1.3	3.9																						
<p>中柱A TRANSOME</p>  <table border="1"> <thead> <tr> <th>Item No</th> <th>Thickness</th> <th>Weight (Kg/6.4m)</th> </tr> </thead> <tbody> <tr> <td>GT08-07</td> <td>1.3</td> <td>4.6</td> </tr> </tbody> </table>	Item No	Thickness	Weight (Kg/6.4m)	GT08-07	1.3	4.6	<p>中柱B TRANSOME</p>  <table border="1"> <thead> <tr> <th>Item No</th> <th>Thickness</th> <th>Weight (Kg/6.4m)</th> </tr> </thead> <tbody> <tr> <td>GT08-08</td> <td>1.3</td> <td>7.7</td> </tr> </tbody> </table>	Item No	Thickness	Weight (Kg/6.4m)	GT08-08	1.3	7.7	<p>中柱C TRANSOME</p>  <table border="1"> <thead> <tr> <th>Item No</th> <th>Thickness</th> <th>Weight (Kg/6.4m)</th> </tr> </thead> <tbody> <tr> <td>GT08-08A</td> <td>1.3</td> <td>7.5</td> </tr> </tbody> </table>	Item No	Thickness	Weight (Kg/6.4m)	GT08-08A	1.3	7.5				
Item No	Thickness	Weight (Kg/6.4m)																						
GT08-07	1.3	4.6																						
Item No	Thickness	Weight (Kg/6.4m)																						
GT08-08	1.3	7.7																						
Item No	Thickness	Weight (Kg/6.4m)																						
GT08-08A	1.3	7.5																						
<p>双开边框 DOUBLE FRAME</p>  <table border="1"> <thead> <tr> <th>Item No</th> <th>Thickness</th> <th>Weight (Kg/6.4m)</th> </tr> </thead> <tbody> <tr> <td>GT08-09</td> <td>1.5</td> <td>10.3</td> </tr> </tbody> </table>	Item No	Thickness	Weight (Kg/6.4m)	GT08-09	1.5	10.3	<p>08门中横 TRANSOME</p>  <table border="1"> <thead> <tr> <th>Item No</th> <th>Thickness</th> <th>Weight (Kg/6.4m)</th> </tr> </thead> <tbody> <tr> <td>GT08-10</td> <td>1.3</td> <td>7.5</td> </tr> </tbody> </table>	Item No	Thickness	Weight (Kg/6.4m)	GT08-10	1.3	7.5	<p>08门光企 DOOR BOTTOM</p>  <table border="1"> <thead> <tr> <th>Item No</th> <th>Thickness</th> <th>Weight (Kg/6.4m)</th> </tr> </thead> <tbody> <tr> <td>GT08-11</td> <td>1.5</td> <td>9.3</td> </tr> </tbody> </table>	Item No	Thickness	Weight (Kg/6.4m)	GT08-11	1.5	9.3				
Item No	Thickness	Weight (Kg/6.4m)																						
GT08-09	1.5	10.3																						
Item No	Thickness	Weight (Kg/6.4m)																						
GT08-10	1.3	7.5																						
Item No	Thickness	Weight (Kg/6.4m)																						
GT08-11	1.5	9.3																						
<p>圆管 PIPE</p>  <table border="1"> <thead> <tr> <th>Item No</th> <th>Thickness</th> <th>Weight (Kg/6.4m)</th> </tr> </thead> <tbody> <tr> <td>GT08-12</td> <td>1.0</td> <td>1.25</td> </tr> </tbody> </table>	Item No	Thickness	Weight (Kg/6.4m)	GT08-12	1.0	1.25	<p>圆管 PIPE</p>  <table border="1"> <thead> <tr> <th>Item No</th> <th>Thickness</th> <th>Weight (Kg/6.4m)</th> </tr> </thead> <tbody> <tr> <td>GT08-12A</td> <td>1.5</td> <td>1.27</td> </tr> </tbody> </table>	Item No	Thickness	Weight (Kg/6.4m)	GT08-12A	1.5	1.27	<p>纱窗料 NET SHUTTER</p>  <table border="1"> <thead> <tr> <th>Item No</th> <th>Thickness</th> <th>Weight (Kg/6.4m)</th> </tr> </thead> <tbody> <tr> <td>GT08-13</td> <td>1.3</td> <td>4.8</td> </tr> </tbody> </table>	Item No	Thickness	Weight (Kg/6.4m)	GT08-13	1.3	4.8				
Item No	Thickness	Weight (Kg/6.4m)																						
GT08-12	1.0	1.25																						
Item No	Thickness	Weight (Kg/6.4m)																						
GT08-12A	1.5	1.27																						
Item No	Thickness	Weight (Kg/6.4m)																						
GT08-13	1.3	4.8																						

* Weight Tolerance of +/- 5% applicable.

GT08 SERIES

反向扇料
DOOR SHUTTER

Item No	Thickness	Weight (Kg/6.4m)
GT08-14	1.3	6.6
	1.5	7.6

08门压条
KICK PLATE

Item No	Thickness	Weight (Kg/6.4m)
GT08-15	1.4	2.1

滑杆
FLAT BAR

Item No	Thickness	Weight (Kg/6.4m)
GT08-16	2.9	0.9

纱窗框料
BOTTOM-NET

Item No	Thickness	Weight (Kg/6.4m)
GT08-17	1.2	5.3

管料
DOURLE FRAME BOX

Item No	Thickness	Weight (Kg/6.4m)
GT08-18	1.5	4.4

边框压条
DOURLE GLAZING BEADING

Item No	Thickness	Weight (Kg/6.4m)
GT08-19	1.3	1.2

压线
BEADING

Item No	Thickness	Weight (Kg/6.4m)
GT08-20	1.1	1.32

压线
BEADING

Item No	Thickness	Weight (Kg/6.4m)
GT08-21	1.0	1.53

20方管
HOLLOW SHCTION

Item No	Thickness	Weight (Kg/6.4m)
2020	1.2	1.64

外边框
FRAME

Item No	Thickness	Weight (Kg/6.4m)
GT08-01A	2.0	11.6

Item No	Thickness	Weight (Kg/6.4m)

Item No	Thickness	Weight (Kg/6.4m)

Item No	Thickness	Weight (Kg/6.4m)

Item No	Thickness	Weight (Kg/6.4m)

Item No	Thickness	Weight (Kg/6.4m)

GT08 SERIES

门中横
DOOR TRASUM

Item No	Thickness	Weight (Kg/6.4m)
WL-2579	1.5	8.4

08门下方
DOOR BOTTOM

Item No	Thickness	Weight (Kg/6.4m)
WL-2345	1.5	8.9

外边框
DOOR OUTER

Item No	Thickness	Weight (Kg/6.4m)
WL-4003	2.0	11.4

门扇料
DOOR SHUTTER

Item No	Thickness	Weight (Kg/6.4m)
WL-4005	1.5	7.9

压线
BEADING

Item No	Thickness	Weight (Kg/6.4m)
GT08-02	1.2	1.4

转单玻料
U CHANNEL

Item No	Thickness	Weight (Kg/6.4m)
WL-2578	1.2	1.49



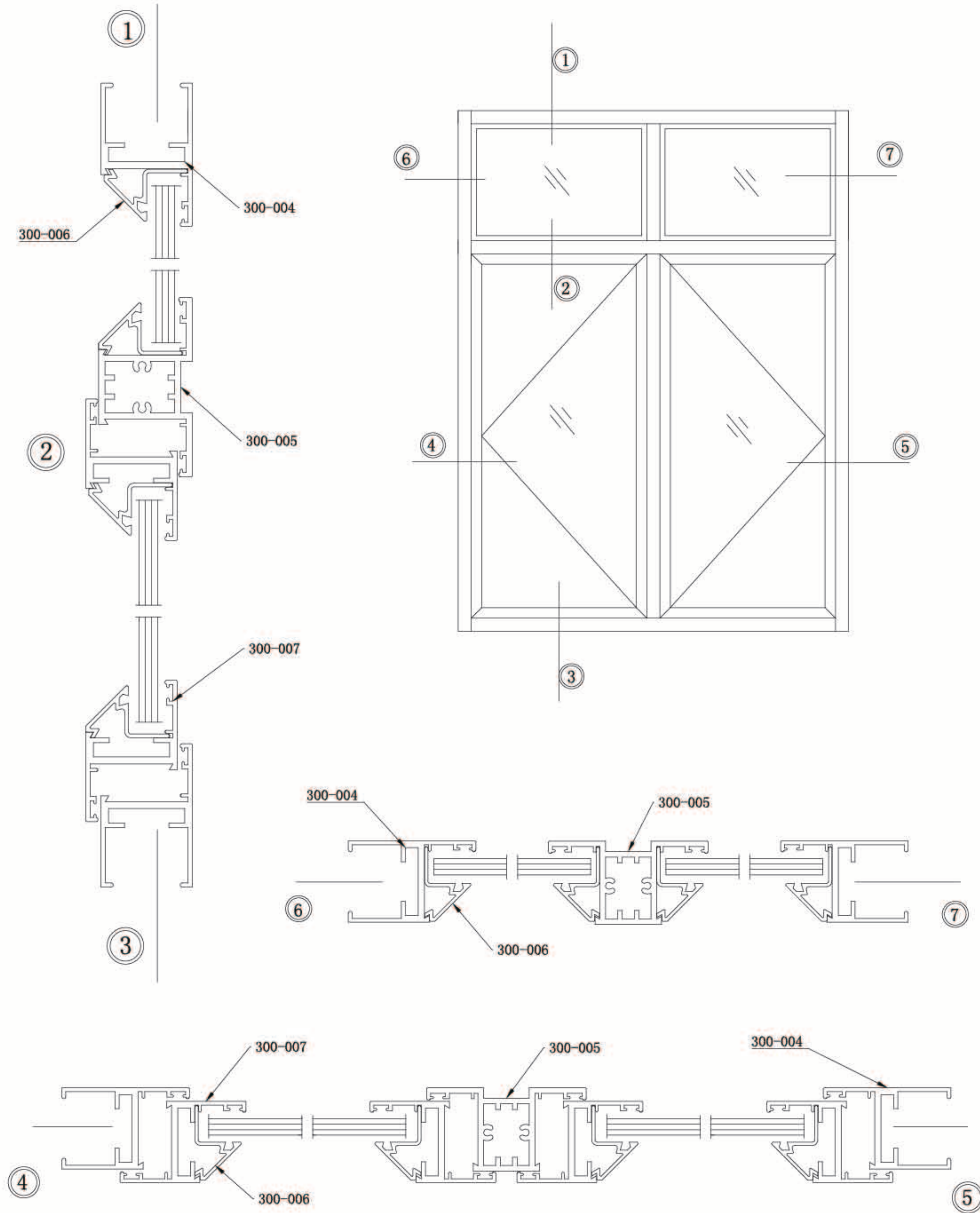

300/90 SERIES FOR PROJECTION

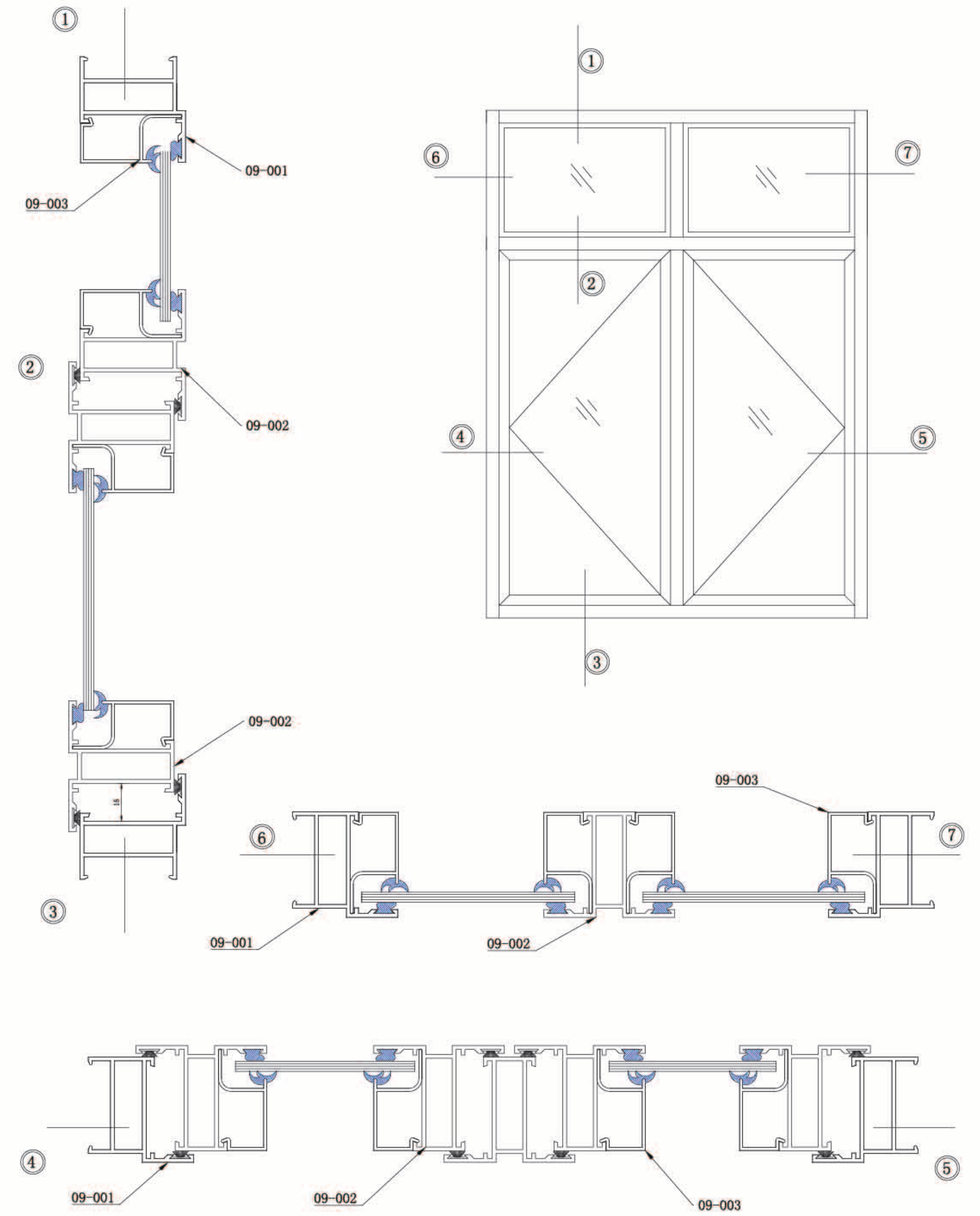

300/90 SERIES FOR PROJECTION

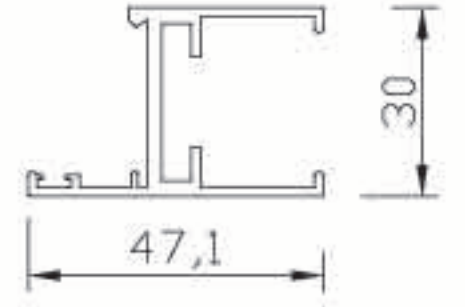
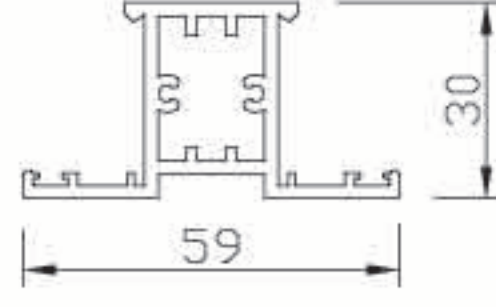

300/90 SERIES FOR PROJECTION

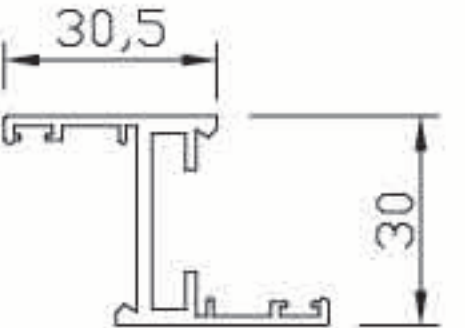
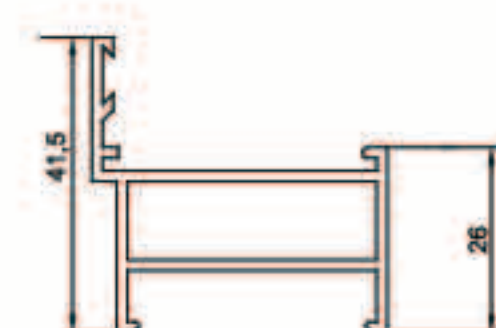
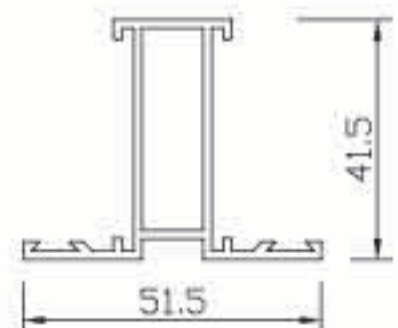
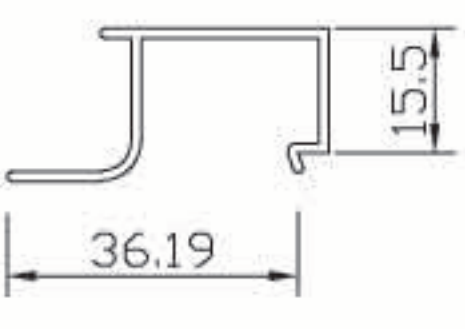
边框 OUTER PRAME 			中柱 TRANSOME/SHUTTER 			压线 BEADING 		
Item No	Thickness	Weight (Kg/6.4m)	Item No	Thickness	Weight (Kg/6.4m)	Item No	Thickness	Weight (Kg/6.4m)
300-004	1.4	4.0	300-005	1.5	4.9	300-006	1.0	1.1
反向扇料 SHUTTER 			边框 OUTER PRAME 			中柱 TRANSOME 		
Item No	Thickness	Weight (Kg/6.4m)	Item No	Thickness	Weight (Kg/6.4m)	Item No	Thickness	Weight (Kg/6.4m)
300-007	1.4	3.6	09-001	1.5	4.2	09-002	1.5	4.5
压线 BEADING 								
Item No	Thickness	Weight (Kg/6.4m)	Item No	Thickness	Weight (Kg/6.4m)	Item No	Thickness	Weight (Kg/6.4m)
09-003	1.2	1.8						
Item No	Thickness	Weight (Kg/6.4m)	Item No	Thickness	Weight (Kg/6.4m)	Item No	Thickness	Weight (Kg/6.4m)
Item No	Thickness	Weight (Kg/6.4m)	Item No	Thickness	Weight (Kg/6.4m)	Item No	Thickness	Weight (Kg/6.4m)

40/50 SERIES FOR PROJECTION

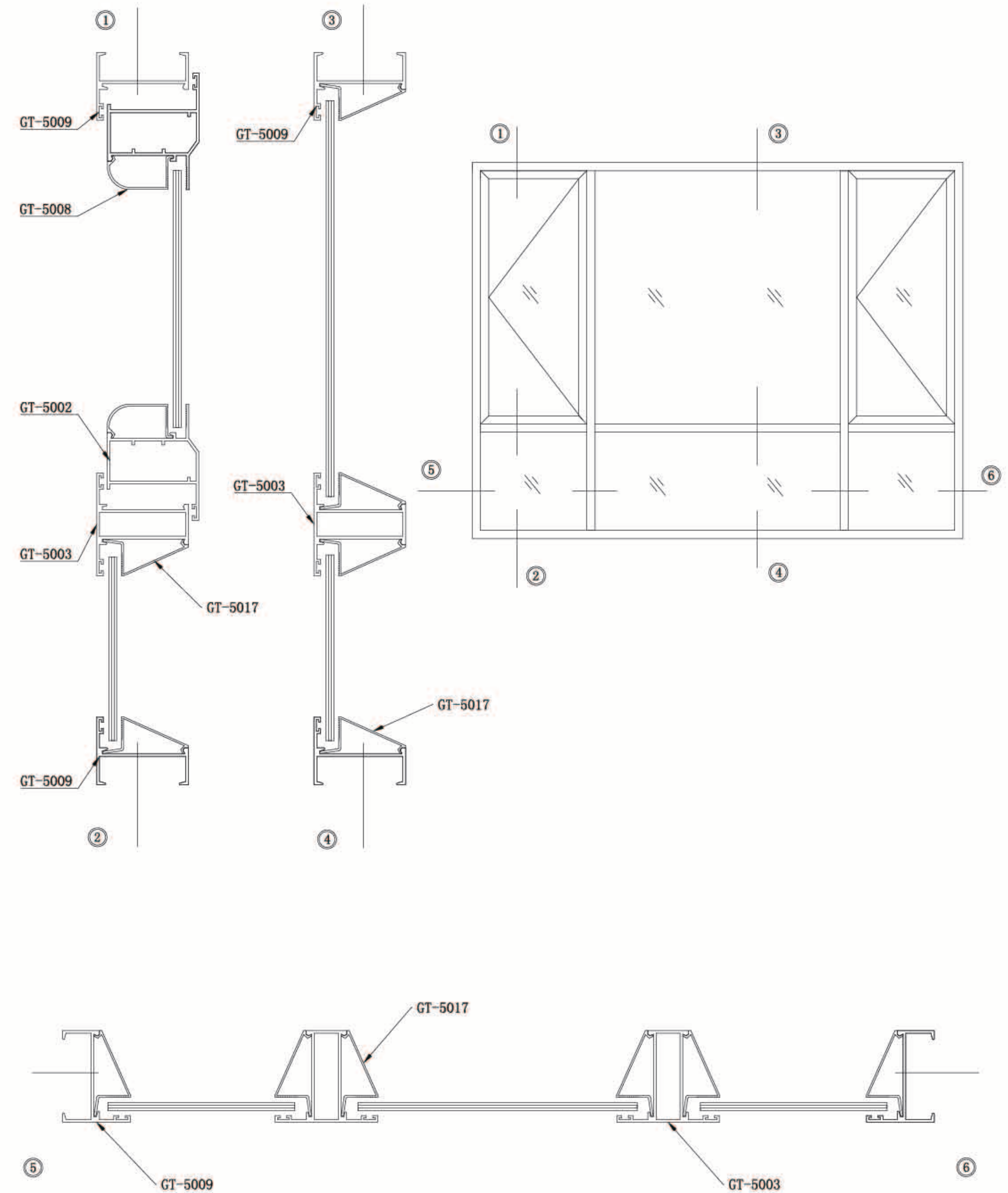

40/50 SERIES FOR PROJECTION

<p>扇料 PJ-SHUTTER</p>	<p>中柱 TRANSOME</p>	<p>斜压线 BEADING</p>																		
<table border="1"> <thead> <tr> <th>Item No</th> <th>Thickness</th> <th>Weight (Kg/6.4m)</th> </tr> </thead> <tbody> <tr> <td>GT-5002</td> <td>1.5</td> <td>5.2</td> </tr> </tbody> </table>	Item No	Thickness	Weight (Kg/6.4m)	GT-5002	1.5	5.2	<table border="1"> <thead> <tr> <th>Item No</th> <th>Thickness</th> <th>Weight (Kg/6.4m)</th> </tr> </thead> <tbody> <tr> <td>GT-5003</td> <td>1.5</td> <td>5.1</td> </tr> </tbody> </table>	Item No	Thickness	Weight (Kg/6.4m)	GT-5003	1.5	5.1	<table border="1"> <thead> <tr> <th>Item No</th> <th>Thickness</th> <th>Weight (Kg/6.4m)</th> </tr> </thead> <tbody> <tr> <td>GT-5007</td> <td>1.1</td> <td>1.1</td> </tr> </tbody> </table>	Item No	Thickness	Weight (Kg/6.4m)	GT-5007	1.1	1.1
Item No	Thickness	Weight (Kg/6.4m)																		
GT-5002	1.5	5.2																		
Item No	Thickness	Weight (Kg/6.4m)																		
GT-5003	1.5	5.1																		
Item No	Thickness	Weight (Kg/6.4m)																		
GT-5007	1.1	1.1																		
<p>圆压线 GT-5008</p>	<p>边框 PJ-OUTER FRAME</p>	<p>单玻斜压线 BEADING</p>																		
<table border="1"> <thead> <tr> <th>Item No</th> <th>Thickness</th> <th>Weight (Kg/6.4m)</th> </tr> </thead> <tbody> <tr> <td>GT-5008</td> <td>1.0</td> <td>1.3</td> </tr> </tbody> </table>	Item No	Thickness	Weight (Kg/6.4m)	GT-5008	1.0	1.3	<table border="1"> <thead> <tr> <th>Item No</th> <th>Thickness</th> <th>Weight (Kg/6.4m)</th> </tr> </thead> <tbody> <tr> <td>GT-5009</td> <td>1.5</td> <td>3.2</td> </tr> </tbody> </table>	Item No	Thickness	Weight (Kg/6.4m)	GT-5009	1.5	3.2	<table border="1"> <thead> <tr> <th>Item No</th> <th>Thickness</th> <th>Weight (Kg/6.4m)</th> </tr> </thead> <tbody> <tr> <td>GT-5017</td> <td>1.1</td> <td>1.3</td> </tr> </tbody> </table>	Item No	Thickness	Weight (Kg/6.4m)	GT-5017	1.1	1.3
Item No	Thickness	Weight (Kg/6.4m)																		
GT-5008	1.0	1.3																		
Item No	Thickness	Weight (Kg/6.4m)																		
GT-5009	1.5	3.2																		
Item No	Thickness	Weight (Kg/6.4m)																		
GT-5017	1.1	1.3																		
<p>单玻圆压线 BEADING</p>	<p>压座 BUTTER FLY</p>	<p>50窗角码 CURTAIN WALL ANGLE</p>																		
<table border="1"> <thead> <tr> <th>Item No</th> <th>Thickness</th> <th>Weight (Kg/6.4m)</th> </tr> </thead> <tbody> <tr> <td>GT-5018</td> <td>1.1</td> <td>1.6</td> </tr> </tbody> </table>	Item No	Thickness	Weight (Kg/6.4m)	GT-5018	1.1	1.6	<table border="1"> <thead> <tr> <th>Item No</th> <th>Thickness</th> <th>Weight (Kg/6.4m)</th> </tr> </thead> <tbody> <tr> <td>GT-5019</td> <td>1.5</td> <td>1.9</td> </tr> </tbody> </table>	Item No	Thickness	Weight (Kg/6.4m)	GT-5019	1.5	1.9	<table border="1"> <thead> <tr> <th>Item No</th> <th>Thickness</th> <th>Weight (Kg/6.4m)</th> </tr> </thead> <tbody> <tr> <td>GT-66X66</td> <td>1.5</td> <td>13.4</td> </tr> </tbody> </table>	Item No	Thickness	Weight (Kg/6.4m)	GT-66X66	1.5	13.4
Item No	Thickness	Weight (Kg/6.4m)																		
GT-5018	1.1	1.6																		
Item No	Thickness	Weight (Kg/6.4m)																		
GT-5019	1.5	1.9																		
Item No	Thickness	Weight (Kg/6.4m)																		
GT-66X66	1.5	13.4																		
<table border="1"> <thead> <tr> <th>Item No</th> <th>Thickness</th> <th>Weight (Kg/6.4m)</th> </tr> </thead> <tbody> <tr> <td></td> <td></td> <td></td> </tr> </tbody> </table>	Item No	Thickness	Weight (Kg/6.4m)				<table border="1"> <thead> <tr> <th>Item No</th> <th>Thickness</th> <th>Weight (Kg/6.4m)</th> </tr> </thead> <tbody> <tr> <td></td> <td></td> <td></td> </tr> </tbody> </table>	Item No	Thickness	Weight (Kg/6.4m)				<table border="1"> <thead> <tr> <th>Item No</th> <th>Thickness</th> <th>Weight (Kg/6.4m)</th> </tr> </thead> <tbody> <tr> <td></td> <td></td> <td></td> </tr> </tbody> </table>	Item No	Thickness	Weight (Kg/6.4m)			
Item No	Thickness	Weight (Kg/6.4m)																		
Item No	Thickness	Weight (Kg/6.4m)																		
Item No	Thickness	Weight (Kg/6.4m)																		
<table border="1"> <thead> <tr> <th>Item No</th> <th>Thickness</th> <th>Weight (Kg/6.4m)</th> </tr> </thead> <tbody> <tr> <td></td> <td></td> <td></td> </tr> </tbody> </table>	Item No	Thickness	Weight (Kg/6.4m)				<table border="1"> <thead> <tr> <th>Item No</th> <th>Thickness</th> <th>Weight (Kg/6.4m)</th> </tr> </thead> <tbody> <tr> <td></td> <td></td> <td></td> </tr> </tbody> </table>	Item No	Thickness	Weight (Kg/6.4m)				<table border="1"> <thead> <tr> <th>Item No</th> <th>Thickness</th> <th>Weight (Kg/6.4m)</th> </tr> </thead> <tbody> <tr> <td></td> <td></td> <td></td> </tr> </tbody> </table>	Item No	Thickness	Weight (Kg/6.4m)			
Item No	Thickness	Weight (Kg/6.4m)																		
Item No	Thickness	Weight (Kg/6.4m)																		
Item No	Thickness	Weight (Kg/6.4m)																		

40/50 SERIES FOR PROJECTION

<p>框料 OUTER PRIME</p>	<p>中柱 TRANSOME</p>	<p>反向扇料 SHUTTER</p>																		
<table border="1"> <thead> <tr> <th>Item No</th> <th>Thickness</th> <th>Weight (Kg/6.4m)</th> </tr> </thead> <tbody> <tr> <td>FFSW-01</td> <td>1.5</td> <td>4.9</td> </tr> </tbody> </table>	Item No	Thickness	Weight (Kg/6.4m)	FFSW-01	1.5	4.9	<table border="1"> <thead> <tr> <th>Item No</th> <th>Thickness</th> <th>Weight (Kg/6.4m)</th> </tr> </thead> <tbody> <tr> <td>FFSW-02</td> <td>1.5</td> <td>5.8</td> </tr> </tbody> </table>	Item No	Thickness	Weight (Kg/6.4m)	FFSW-02	1.5	5.8	<table border="1"> <thead> <tr> <th>Item No</th> <th>Thickness</th> <th>Weight (Kg/6.4m)</th> </tr> </thead> <tbody> <tr> <td>FFSW-03</td> <td>1.5</td> <td>5.8</td> </tr> </tbody> </table>	Item No	Thickness	Weight (Kg/6.4m)	FFSW-03	1.5	5.8
Item No	Thickness	Weight (Kg/6.4m)																		
FFSW-01	1.5	4.9																		
Item No	Thickness	Weight (Kg/6.4m)																		
FFSW-02	1.5	5.8																		
Item No	Thickness	Weight (Kg/6.4m)																		
FFSW-03	1.5	5.8																		
<p>压线 BEADING</p>	<p>插板 PLATE</p>	<p>插板 PLATE</p>																		
<table border="1"> <thead> <tr> <th>Item No</th> <th>Thickness</th> <th>Weight (Kg/6.4m)</th> </tr> </thead> <tbody> <tr> <td>FFSW-04</td> <td>1.5</td> <td>1.8</td> </tr> </tbody> </table>	Item No	Thickness	Weight (Kg/6.4m)	FFSW-04	1.5	1.8	<table border="1"> <thead> <tr> <th>Item No</th> <th>Thickness</th> <th>Weight (Kg/6.4m)</th> </tr> </thead> <tbody> <tr> <td>P201</td> <td>1.6</td> <td>1.9</td> </tr> </tbody> </table>	Item No	Thickness	Weight (Kg/6.4m)	P201	1.6	1.9	<table border="1"> <thead> <tr> <th>Item No</th> <th>Thickness</th> <th>Weight (Kg/6.4m)</th> </tr> </thead> <tbody> <tr> <td>P202</td> <td>1.6</td> <td>1.8</td> </tr> </tbody> </table>	Item No	Thickness	Weight (Kg/6.4m)	P202	1.6	1.8
Item No	Thickness	Weight (Kg/6.4m)																		
FFSW-04	1.5	1.8																		
Item No	Thickness	Weight (Kg/6.4m)																		
P201	1.6	1.9																		
Item No	Thickness	Weight (Kg/6.4m)																		
P202	1.6	1.8																		



PARTITION SERIES

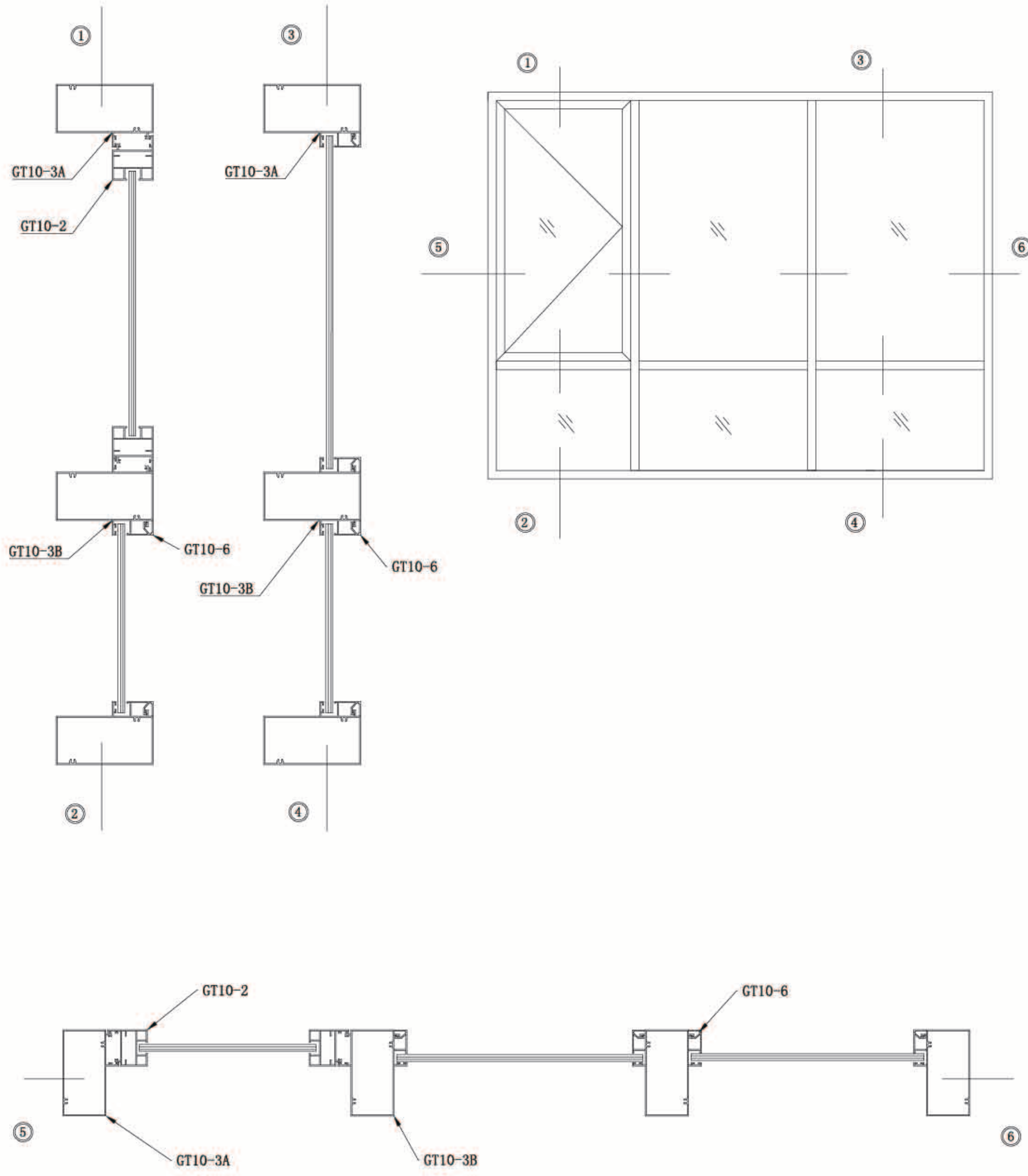

PARTITION SERIES

Item No	Thickness	Weight (Kg/6.4m)
GT10-1	1.2	6.2
GT10-2	1.2	5.2
GT10-3A	1.2	7.7
GT10-3B	1.2	8.4
GT10-4A	1.2	6.4
GT10-4B	1.2	7.1
GT10-5A	1.5	9.38
GT10-5B	1.5	10.3
GT10-6	1.2	1.6

* Weight Tolerance of +/- 5% applicable.

PARTITION SERIES

100边框
OUTER FRAME (38B15)(GT001)

Item No	Thickness	Weight (Kg/6.4m)
10044A	1.2	7.0
	1.5	8.9

100中柱
TRANSOME (38B15)(GT001)

Item No	Thickness	Weight (Kg/6.4m)
10044B	1.2	7.8
	1.5	9.5

80边框
OUTER FRAME (38B15)(GT001)

Item No	Thickness	Weight (Kg/6.4m)
8040A	1.2	6.13
	1.5	7.3

80中柱
TRANSOME (38B15)(GT001)

Item No	Thickness	Weight (Kg/6.4m)
8040B	1.2	6.8
	1.5	8.3

方压线
BEADING

Item No	Thickness	Weight (Kg/6.4m)
GT001	1.0	2

斜压线
BEADING

Item No	Thickness	Weight (Kg/6.4m)
38B15	1.0	1

纱窗料
NET

Item No	Thickness	Weight (Kg/6.4m)
7610	1.2	1.4

45°转角
CORNER POST

Item No	Thickness	Weight (Kg/6.4m)
11555	1.8	11.2

90°转角
CORNER POST

Item No	Thickness	Weight (Kg/6.4m)
7609	1.2	7.5

45°转角
CORNER POST

Item No	Thickness	Weight (Kg/6.4m)
7611	1.2	6.8

Item No	Thickness	Weight (Kg/6.4m)

Item No	Thickness	Weight (Kg/6.4m)

Item No	Thickness	Weight (Kg/6.4m)

Item No	Thickness	Weight (Kg/6.4m)

Item No	Thickness	Weight (Kg/6.4m)

PARTITION SERIES

60中柱
TRANSOME (01-142)

Item No	Thickness	Weight (Kg/6.4m)
01-139	1.2	5.2

60边框
OUTER FRAME (01-142)

Item No	Thickness	Weight (Kg/6.4m)
01-140	1.2	4.2

压线
BEADING

Item No	Thickness	Weight (Kg/6.4m)
01-142	1.0	1.1

中柱
TRANSOME (46-6)(68-002)

Item No	Thickness	Weight (Kg/6.4m)
68-001	1.2	5.5

边框
OUTER FRAME (46-6)(68-002)

Item No	Thickness	Weight (Kg/6.4m)
68-001A	0.9	3.7

方压线
BEADING

Item No	Thickness	Weight (Kg/6.4m)
46-6	0.8	0.9

斜压线
BEADING

Item No	Thickness	Weight (Kg/6.4m)
68-002	0.8	0.7

中柱
TRANSOME (38B15)

Item No	Thickness	Weight (Kg/6.4m)
68-003	1.2	6.3

中柱
TRANSOME (46-6)(68-002)

Item No	Thickness	Weight (Kg/6.4m)
68-004	1.0	4.6

边框
DOOR FRAME (46-6)(68-002)

Item No	Thickness	Weight (Kg/6.4m)
68-005	1.5	7.1

扇料
SHUTTER

Item No	Thickness	Weight (Kg/6.4m)
1001-1	1.5	4.0

Item No	Thickness	Weight (Kg/6.4m)

Item No	Thickness	Weight (Kg/6.4m)

Item No	Thickness	Weight (Kg/6.4m)

Item No	Thickness	Weight (Kg/6.4m)

PARTITION SERIES

46 COLUMN DOOR SERIES

60边框
OUTER FRAME

Item No	Thickness	Weight (Kg/6.4m)
01-180	1.1	4.2

转角料
HALF ROUND

Item No	Thickness	Weight (Kg/6.4m)
CS-01	0.9	1.9

中柱
DOUBLE GLAZING PARTITION SECTION

Item No	Thickness	Weight (Kg/6.4m)
FB-01	1.4	9.8

中柱压板
COVER

Item No	Thickness	Weight (Kg/6.4m)
FB-02	1.3	2.7

收口
BEADING

Item No	Thickness	Weight (Kg/6.4m)
FB-03	1.4	1.6

Item No	Thickness	Weight (Kg/6.4m)

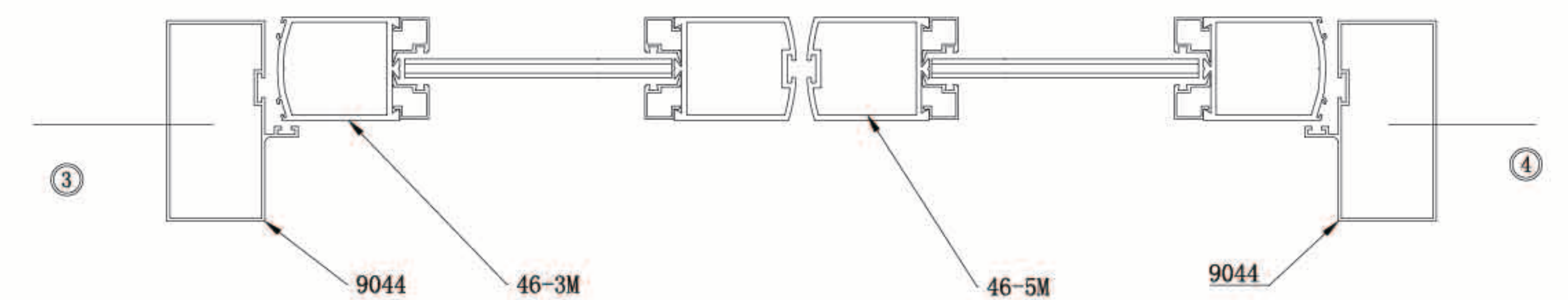
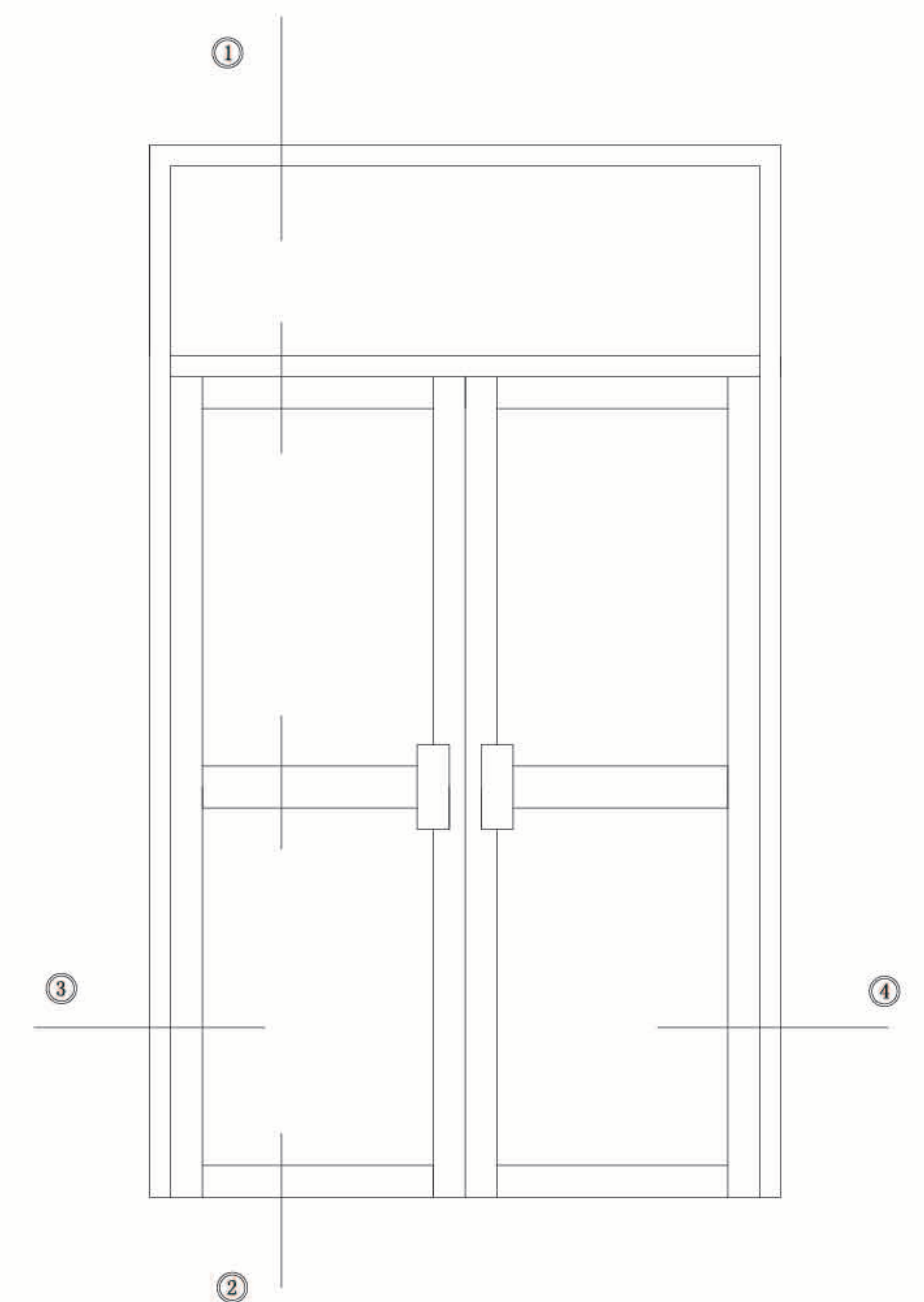
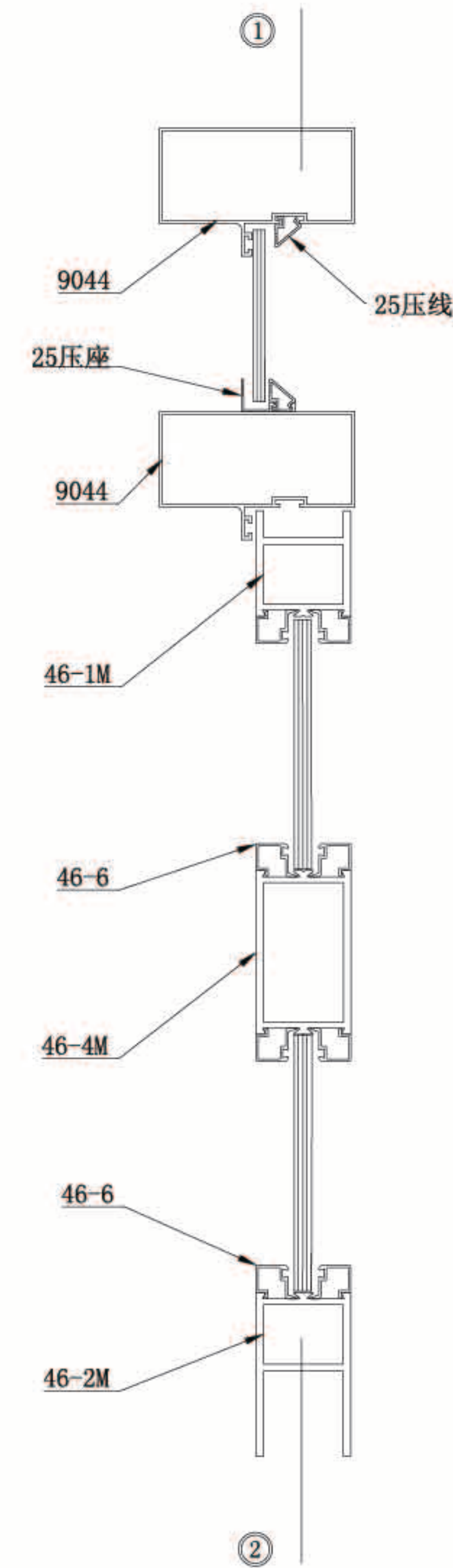



46 COLUMN DOOR SERTES

<p>门上方 TOP FRAME</p>	<p>门下方 BOTTOM FRAME</p>	<p>门企 BOUBLE BRUSH</p>																		
<table border="1"> <thead> <tr> <th>Item No</th> <th>Thickness</th> <th>Weight (Kg/6.4m)</th> </tr> </thead> <tbody> <tr> <td>46-1M</td> <td>2.6</td> <td>8.7</td> </tr> </tbody> </table>	Item No	Thickness	Weight (Kg/6.4m)	46-1M	2.6	8.7	<table border="1"> <thead> <tr> <th>Item No</th> <th>Thickness</th> <th>Weight (Kg/6.4m)</th> </tr> </thead> <tbody> <tr> <td>46-2M</td> <td>2.6</td> <td>11.4</td> </tr> </tbody> </table>	Item No	Thickness	Weight (Kg/6.4m)	46-2M	2.6	11.4	<table border="1"> <thead> <tr> <th>Item No</th> <th>Thickness</th> <th>Weight (Kg/6.4m)</th> </tr> </thead> <tbody> <tr> <td>46-3M</td> <td>2.6</td> <td>9</td> </tr> </tbody> </table>	Item No	Thickness	Weight (Kg/6.4m)	46-3M	2.6	9
Item No	Thickness	Weight (Kg/6.4m)																		
46-1M	2.6	8.7																		
Item No	Thickness	Weight (Kg/6.4m)																		
46-2M	2.6	11.4																		
Item No	Thickness	Weight (Kg/6.4m)																		
46-3M	2.6	9																		
<p>门中柱 TRANSOME</p>	<p>门毛企 SINGLE BRUSH</p>	<p>方压线 BEADING</p>																		
<table border="1"> <thead> <tr> <th>Item No</th> <th>Thickness</th> <th>Weight (Kg/6.4m)</th> </tr> </thead> <tbody> <tr> <td>46-4M</td> <td>2.6</td> <td>11.7</td> </tr> </tbody> </table>	Item No	Thickness	Weight (Kg/6.4m)	46-4M	2.6	11.7	<table border="1"> <thead> <tr> <th>Item No</th> <th>Thickness</th> <th>Weight (Kg/6.4m)</th> </tr> </thead> <tbody> <tr> <td>46-5M</td> <td>2.6</td> <td>9.4</td> </tr> </tbody> </table>	Item No	Thickness	Weight (Kg/6.4m)	46-5M	2.6	9.4	<table border="1"> <thead> <tr> <th>Item No</th> <th>Thickness</th> <th>Weight (Kg/6.4m)</th> </tr> </thead> <tbody> <tr> <td>46-6</td> <td>0.8</td> <td>0.9</td> </tr> </tbody> </table>	Item No	Thickness	Weight (Kg/6.4m)	46-6	0.8	0.9
Item No	Thickness	Weight (Kg/6.4m)																		
46-4M	2.6	11.7																		
Item No	Thickness	Weight (Kg/6.4m)																		
46-5M	2.6	9.4																		
Item No	Thickness	Weight (Kg/6.4m)																		
46-6	0.8	0.9																		
<p>扇料 DOOR FRAME/SHUTTER</p>	<p>门上方 TOP FRAME</p>	<p>门下方 BOTTOM FRAME</p>																		
<table border="1"> <thead> <tr> <th>Item No</th> <th>Thickness</th> <th>Weight (Kg/6.4m)</th> </tr> </thead> <tbody> <tr> <td>46-7</td> <td>1.2</td> <td>5</td> </tr> </tbody> </table>	Item No	Thickness	Weight (Kg/6.4m)	46-7	1.2	5	<table border="1"> <thead> <tr> <th>Item No</th> <th>Thickness</th> <th>Weight (Kg/6.4m)</th> </tr> </thead> <tbody> <tr> <td>46-1MA</td> <td>1.5</td> <td>5.8</td> </tr> </tbody> </table>	Item No	Thickness	Weight (Kg/6.4m)	46-1MA	1.5	5.8	<table border="1"> <thead> <tr> <th>Item No</th> <th>Thickness</th> <th>Weight (Kg/6.4m)</th> </tr> </thead> <tbody> <tr> <td>46-2MA</td> <td>1.5</td> <td>7.3</td> </tr> </tbody> </table>	Item No	Thickness	Weight (Kg/6.4m)	46-2MA	1.5	7.3
Item No	Thickness	Weight (Kg/6.4m)																		
46-7	1.2	5																		
Item No	Thickness	Weight (Kg/6.4m)																		
46-1MA	1.5	5.8																		
Item No	Thickness	Weight (Kg/6.4m)																		
46-2MA	1.5	7.3																		
<p>门企 BOUBLE BRUSH</p>	<p>门中柱 TRANSOME</p>	<p>门毛企 SINGLE BRUSH</p>																		
<table border="1"> <thead> <tr> <th>Item No</th> <th>Thickness</th> <th>Weight (Kg/6.4m)</th> </tr> </thead> <tbody> <tr> <td>46-3MA</td> <td>1.5</td> <td>5.8</td> </tr> </tbody> </table>	Item No	Thickness	Weight (Kg/6.4m)	46-3MA	1.5	5.8	<table border="1"> <thead> <tr> <th>Item No</th> <th>Thickness</th> <th>Weight (Kg/6.4m)</th> </tr> </thead> <tbody> <tr> <td>46-4MA</td> <td>1.5</td> <td>7.8</td> </tr> </tbody> </table>	Item No	Thickness	Weight (Kg/6.4m)	46-4MA	1.5	7.8	<table border="1"> <thead> <tr> <th>Item No</th> <th>Thickness</th> <th>Weight (Kg/6.4m)</th> </tr> </thead> <tbody> <tr> <td>46-5MA</td> <td>1.5</td> <td>6</td> </tr> </tbody> </table>	Item No	Thickness	Weight (Kg/6.4m)	46-5MA	1.5	6
Item No	Thickness	Weight (Kg/6.4m)																		
46-3MA	1.5	5.8																		
Item No	Thickness	Weight (Kg/6.4m)																		
46-4MA	1.5	7.8																		
Item No	Thickness	Weight (Kg/6.4m)																		
46-5MA	1.5	6																		
<p>边框 OUTER FRAME</p>	<p>门料 SHUTTER</p>																			
<table border="1"> <thead> <tr> <th>Item No</th> <th>Thickness</th> <th>Weight (Kg/6.4m)</th> </tr> </thead> <tbody> <tr> <td>9044</td> <td>1.45</td> <td>7.6</td> </tr> </tbody> </table>	Item No	Thickness	Weight (Kg/6.4m)	9044	1.45	7.6	<table border="1"> <thead> <tr> <th>Item No</th> <th>Thickness</th> <th>Weight (Kg/6.4m)</th> </tr> </thead> <tbody> <tr> <td>46-8</td> <td>2.7</td> <td>18</td> </tr> </tbody> </table>	Item No	Thickness	Weight (Kg/6.4m)	46-8	2.7	18							
Item No	Thickness	Weight (Kg/6.4m)																		
9044	1.45	7.6																		
Item No	Thickness	Weight (Kg/6.4m)																		
46-8	2.7	18																		

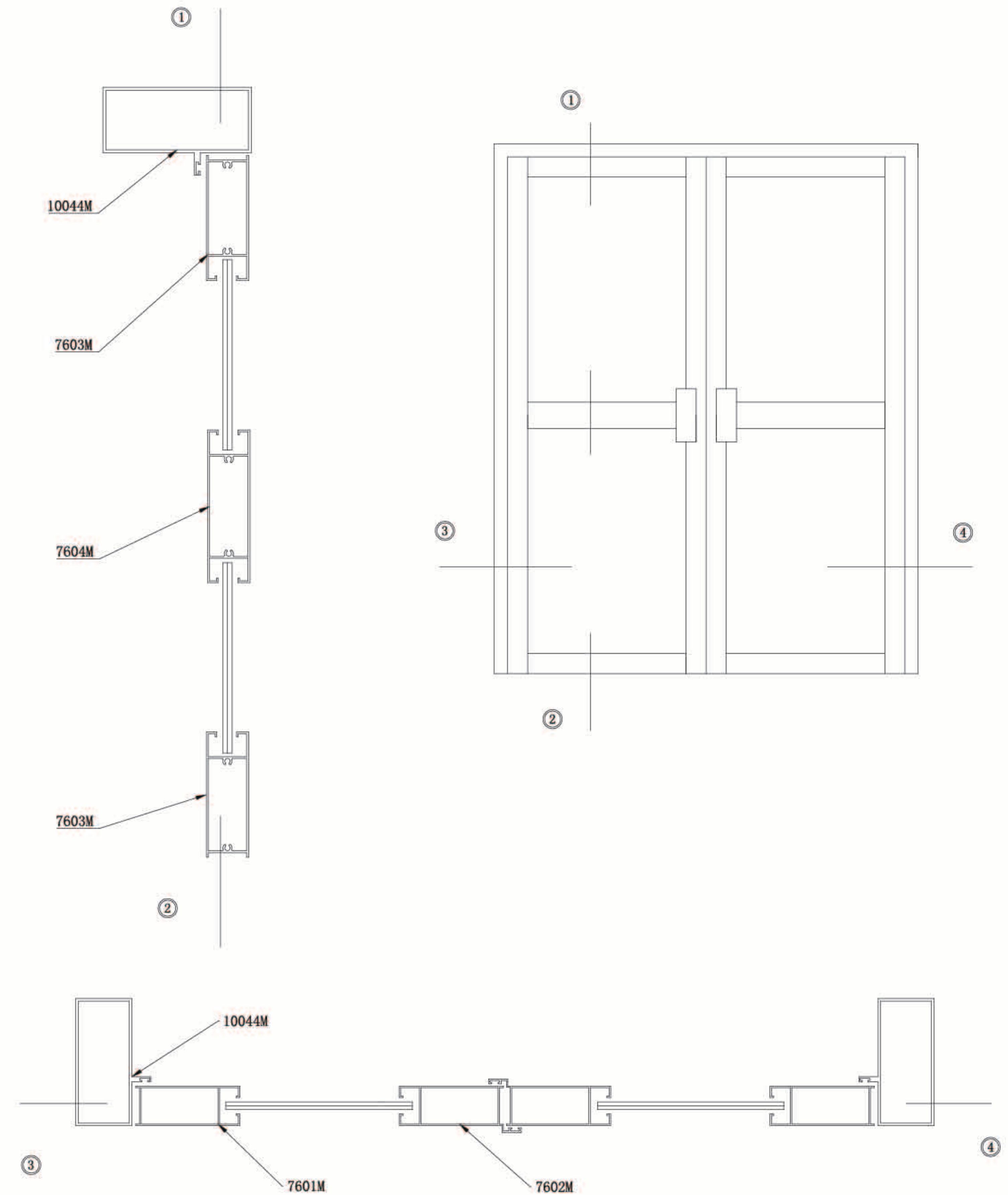
76 COLUMN DOOR SERTES

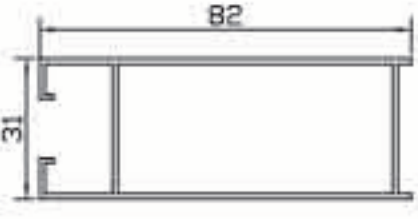
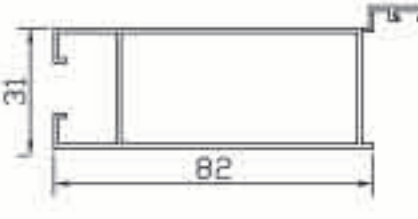

76 COLUMN DOOR SERTES

门光企 SHUTTER			门勾企 LOCKING CHANNEL			门下方 SHUTTER		
								
Item No	Thickness	Weight (Kg/6.4m)	Item No	Thickness	Weight (Kg/6.4m)	Item No	Thickness	Weight (Kg/6.4m)
7601M	1.2	5.25	7602M	1.2	5.8	7603M	1.2	5.2

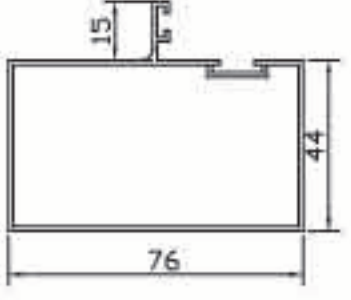
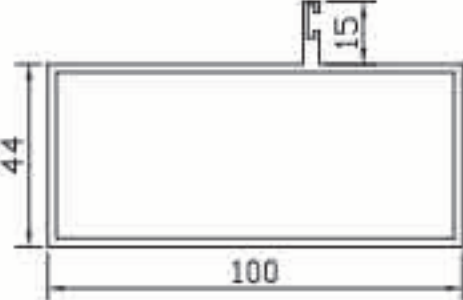
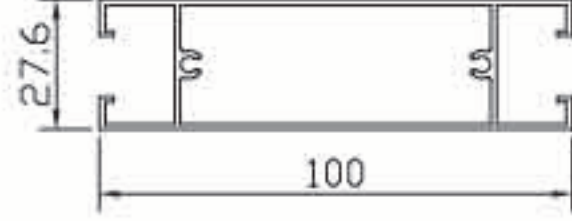
门勾企 OUTER FRAME			门框料 OUTER FRAME			门中柱 TRANSOME		
								
Item No	Thickness	Weight (Kg/6.4m)	Item No	Thickness	Weight (Kg/6.4m)	Item No	Thickness	Weight (Kg/6.4m)
7644M	1.2	5.9	10044M	2.0	11.2	7604M	1.2	6.3

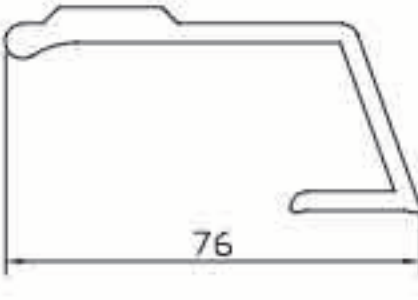
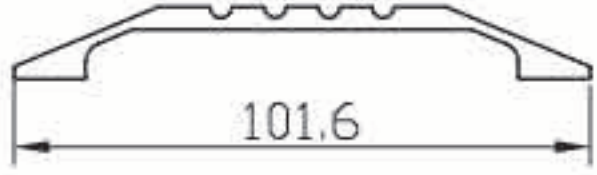
门把手 PUSH-PLATE			脚踏板 KICK PLATE					
								
Item No	Thickness	Weight (Kg/6.4m)	Item No	Thickness	Weight (Kg/6.4m)	Item No	Thickness	Weight (Kg/6.4m)
120	3.5	9	01-014	4.0	6.8			

Item No	Thickness	Weight (Kg/6.4m)	Item No	Thickness	Weight (Kg/6.4m)	Item No	Thickness	Weight (Kg/6.4m)

Item No	Thickness	Weight (Kg/6.4m)	Item No	Thickness	Weight (Kg/6.4m)	Item No	Thickness	Weight (Kg/6.4m)



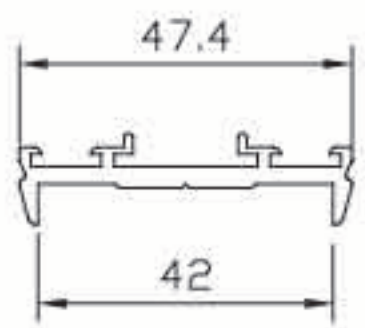
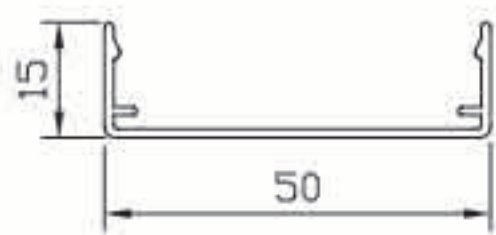
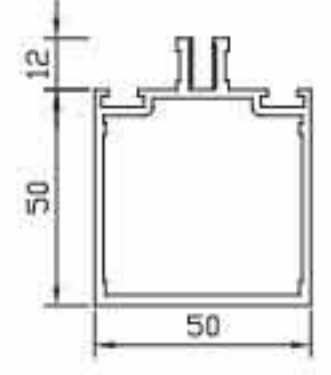
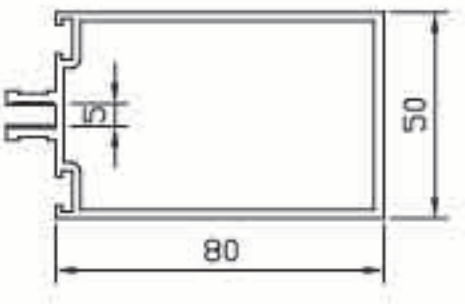
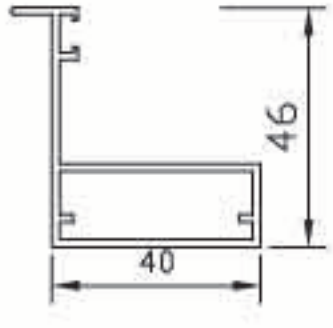

CURTAIN WALL SERIES

<p>压板 INNER COVER</p> 			<p>压盖 OUTER COVER</p> 			<p>副梁 FRAME</p> 		
Item No	Thickness	Weight (Kg/6.4m)	Item No	Thickness	Weight (Kg/6.4m)	Item No	Thickness	Weight (Kg/6.4m)
01-282	2.5	3.4	01-280	1.2	1.8	09-110	2.0	9.3
							3.0	12.2
<p>主梁 FRAME</p> 			<p>扇料 SHUTTER</p> 					
Item No	Thickness	Weight (Kg/6.4m)	Item No	Thickness	Weight (Kg/6.4m)	Item No	Thickness	Weight (Kg/6.4m)
09-111	2.0	11.3	1001-1	1.5	4.0			
	3.0	15.3						
Item No	Thickness	Weight (Kg/6.4m)	Item No	Thickness	Weight (Kg/6.4m)	Item No	Thickness	Weight (Kg/6.4m)
Item No	Thickness	Weight (Kg/6.4m)	Item No	Thickness	Weight (Kg/6.4m)	Item No	Thickness	Weight (Kg/6.4m)
Item No	Thickness	Weight (Kg/6.4m)	Item No	Thickness	Weight (Kg/6.4m)	Item No	Thickness	Weight (Kg/6.4m)
Item No	Thickness	Weight (Kg/6.4m)	Item No	Thickness	Weight (Kg/6.4m)	Item No	Thickness	Weight (Kg/6.4m)

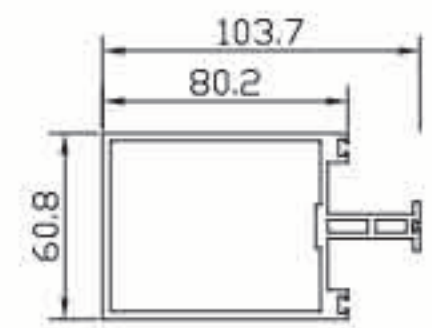
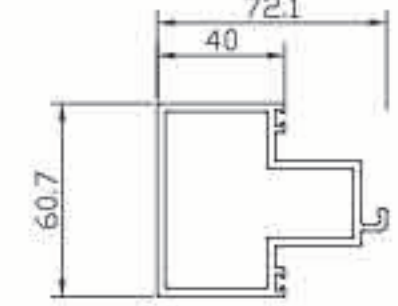
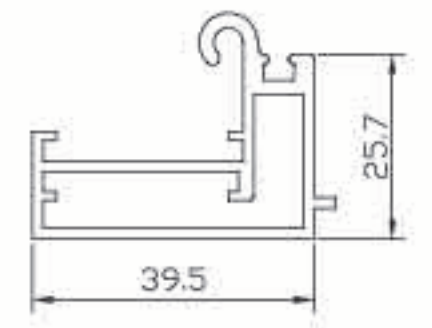
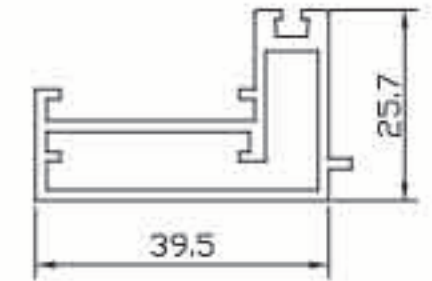
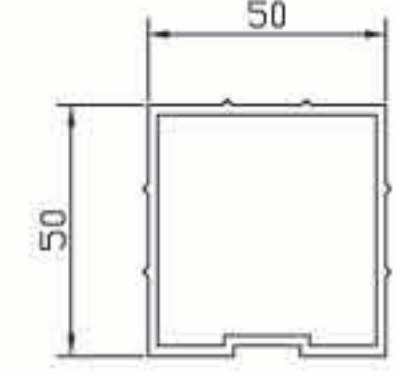
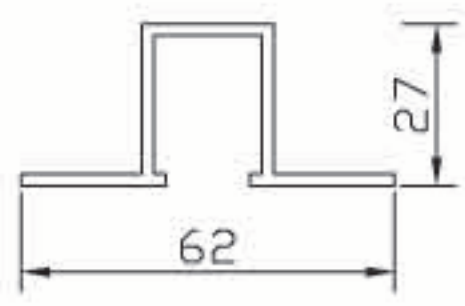
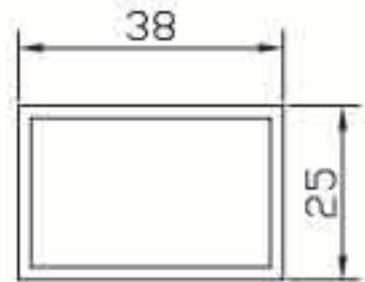
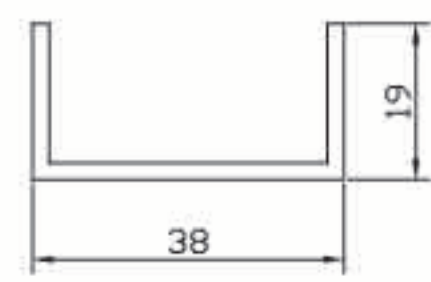
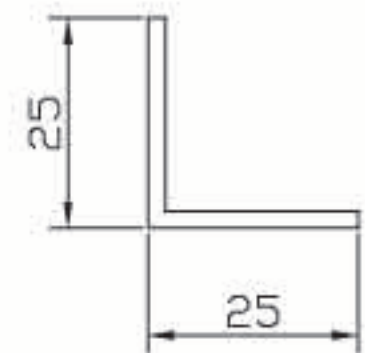
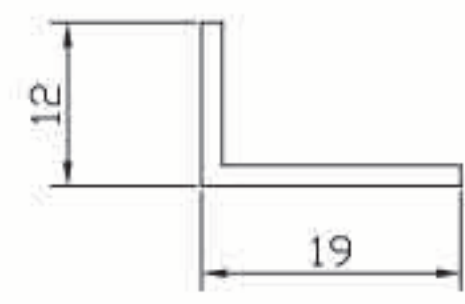
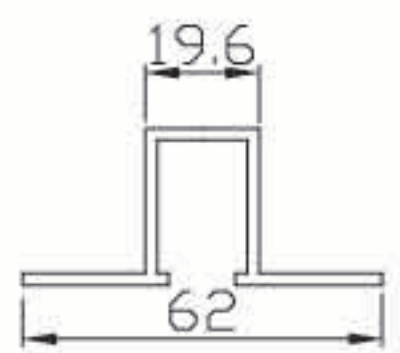
CURTAIN WALL SERIES

<p>主梁 FRAME</p> 			<p>副框料 FRAME</p> 			<p>扇料 SHUTTER</p> 		
Item No	Thickness	Weight (Kg/6.4m)	Item No	Thickness	Weight (Kg/6.4m)	Item No	Thickness	Weight (Kg/6.4m)
SKY-01	2.5	16.0	SKY-02	2.5	11.4	SKY-03	1.5	4.5
<p>扇料 SHUTTER</p> 			<p>拼接内管料 JOINER</p> 			<p>压板 BEADING</p> 		
Item No	Thickness	Weight (Kg/6.4m)	Item No	Thickness	Weight (Kg/6.4m)	Item No	Thickness	Weight (Kg/6.4m)
SKY-04	1.5	4.0	SKY-05	2.0	6.9	SKY-06	2.0	4.1
<p>3825方管 HOLLOW SECTION</p> 			<p>3820U槽 U CHANNEL</p> 			<p>25角铝 ANGLE</p> 		
Item No	Thickness	Weight (Kg/6.4m)	Item No	Thickness	Weight (Kg/6.4m)	Item No	Thickness	Weight (Kg/6.4m)
SKY-07	1.8	3.8	SKY-08	2.0	2.57	SKY-09	2.0	1.7
<p>角铝 ANGLE</p> 			<p>高压板 BEADING</p> 					
Item No	Thickness	Weight (Kg/6.4m)	Item No	Thickness	Weight (Kg/6.4m)	Item No	Thickness	Weight (Kg/6.4m)
SKY-10	1.5	0.8	SKY-06A	2.0	4.1			
Item No	Thickness	Weight (Kg/6.4m)	Item No	Thickness	Weight (Kg/6.4m)	Item No	Thickness	Weight (Kg/6.4m)
Item No	Thickness	Weight (Kg/6.4m)	Item No	Thickness	Weight (Kg/6.4m)	Item No	Thickness	Weight (Kg/6.4m)

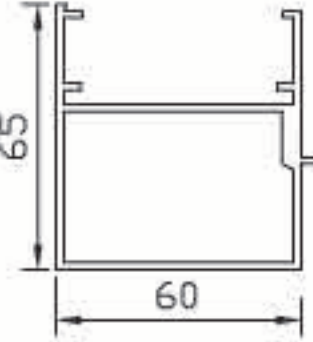
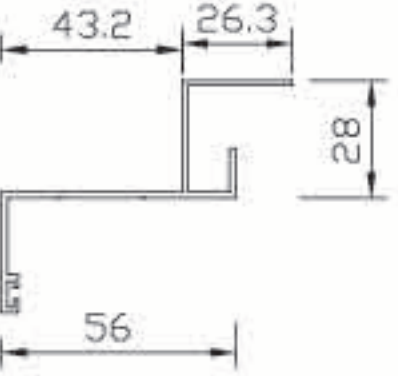
CURTAIN WALL SERIES

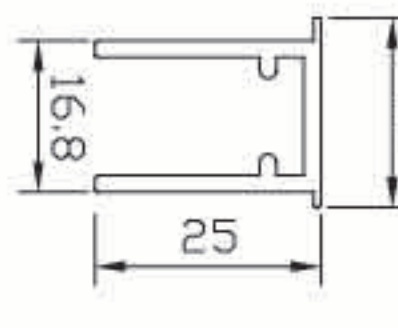
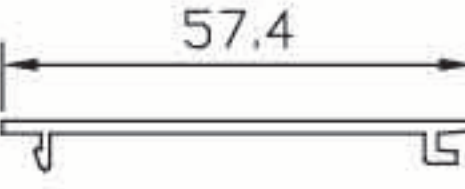
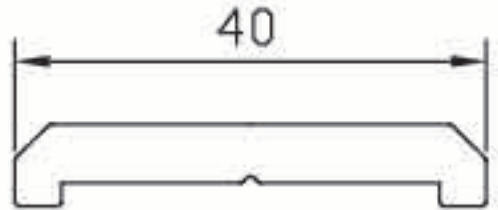
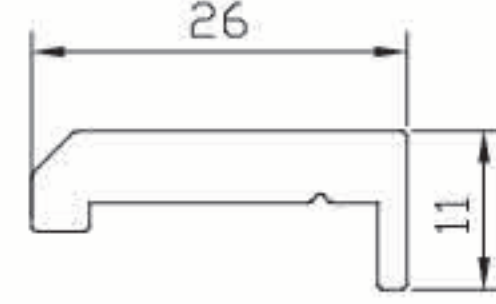
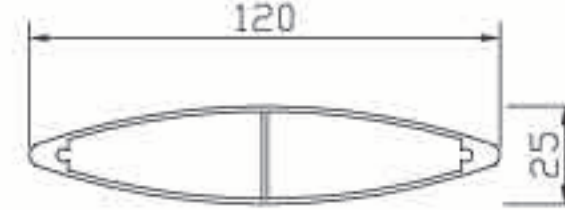
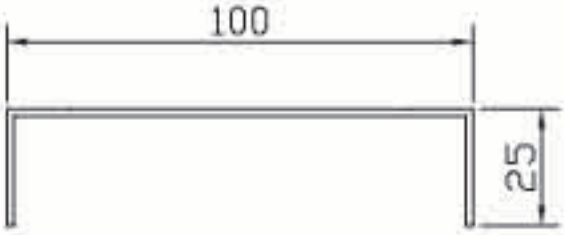
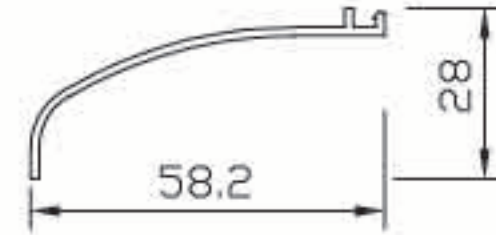
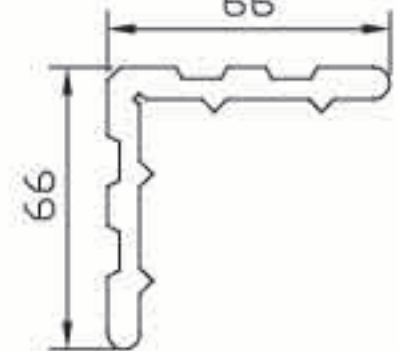
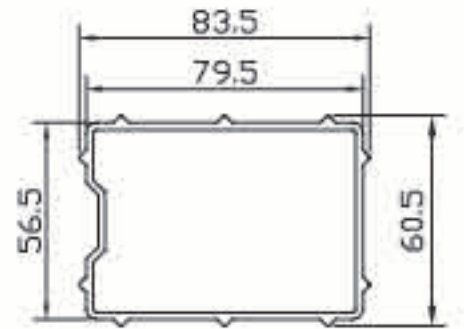
主梁管 CURTAIN WALL FRAME 			横梁 CURTAIN WALL FRAME-HORIZONTAL 			框料 PJ OUTER FRAME 		
Item No	Thickness	Weight (Kg/6.4m)	Item No	Thickness	Weight (Kg/6.4m)	Item No	Thickness	Weight (Kg/6.4m)
GT9001	2.5	12.7	GT-9002	1.8	9.2	GT9003	1.5	4.05
扇料 PJ SHUTTER 			压线 PJ CHANNEL 			横梁盖板 COVER 		
Item No	Thickness	Weight (Kg/6.4m)	Item No	Thickness	Weight (Kg/6.4m)	Item No	Thickness	Weight (Kg/6.4m)
GT9004	1.5	5.3	GT9007	1.9	2.45	GT9008	1.6	1.95
压条 FLAT BAR 			压条 ANGLE 			管百叶 SUN BRAKER 		
Item No	Thickness	Weight (Kg/6.4m)	Item No	Thickness	Weight (Kg/6.4m)	Item No	Thickness	Weight (Kg/6.4m)
GT9009	5	3.8	GT9010	5	2.7	GT9011	1.5	7.9
1025U槽 COVER 			挡水压条 BEADING 			66角码 ANGEL FOR SHUTTER 		
Item No	Thickness	Weight (Kg/6.4m)	Item No	Thickness	Weight (Kg/6.4m)	Item No	Thickness	Weight (Kg/6.4m)
GT9012	1.5	4.1	GT9016	1.4	1.85	GT66X11	11	15.2
拼接内管料 JOINER 								
Item No	Thickness	Weight (Kg/6.4m)	Item No	Thickness	Weight (Kg/6.4m)	Item No	Thickness	Weight (Kg/6.4m)
YXC9013	2	10.5						

CURTAIN WALL SERIES

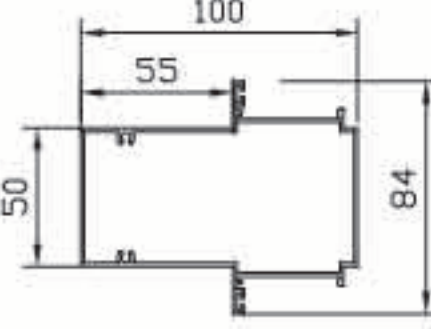
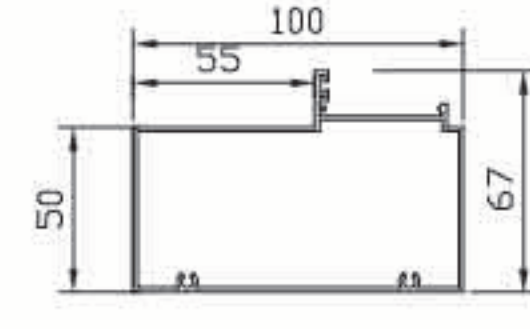
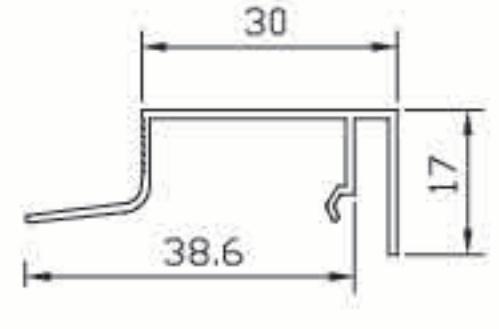
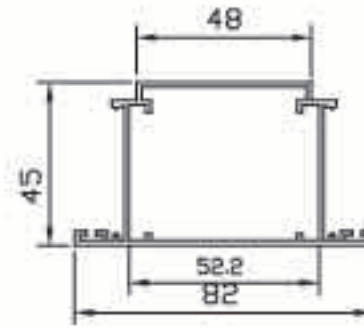
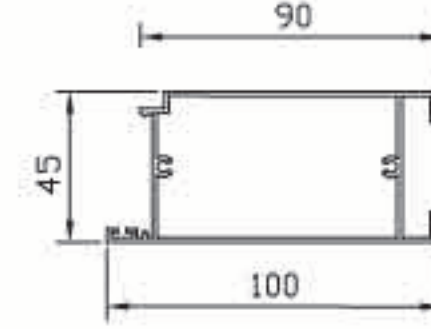
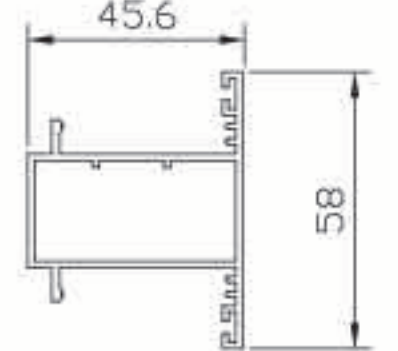
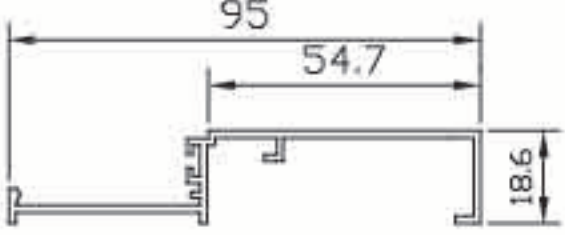
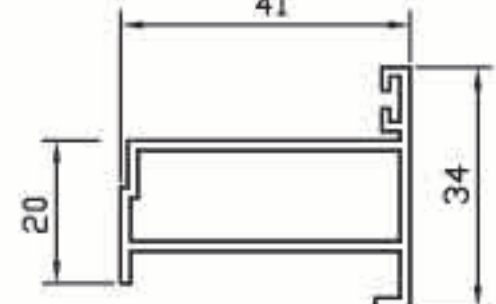
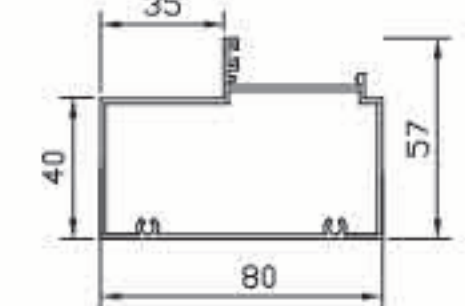
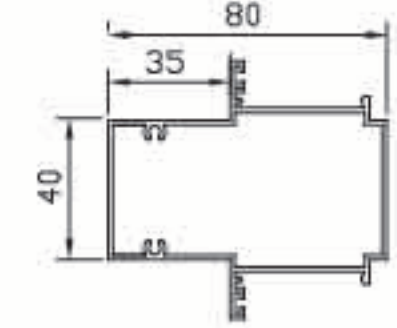
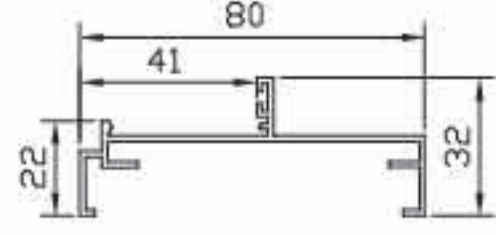
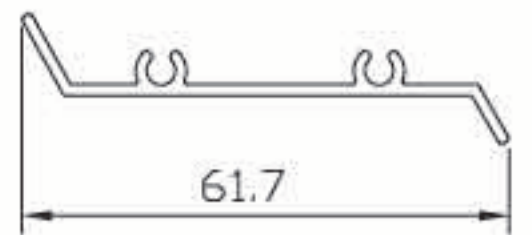
100中柱 FRAME TRASUM 			100外框 FRAME OUTER 			中柱 FRAME & DOOR BANDING 		
Item No	Thickness	Weight (Kg/6.4m)	Item No	Thickness	Weight (Kg/6.4m)	Item No	Thickness	Weight (Kg/6.4m)
GT1001	1.5	10	GT1002	1.5	9.1	GT1003	1.5	1.58
门中横 DOOR HT & TOP 			门扇料 DOOR BOTTOM 			扇窗料 DOUBLE DOOR MEETING CHANNEL 		
Item No	Thickness	Weight (Kg/6.4m)	Item No	Thickness	Weight (Kg/6.4m)	Item No	Thickness	Weight (Kg/6.4m)
GT1004	1.5	6.9	GT1005	1.5	8.5	GT1006	1.5	5.5
框料 COVER 			转换料 PJ OUTER 			80外框 FRAME OUTER 		
Item No	Thickness	Weight (Kg/6.4m)	Item No	Thickness	Weight (Kg/6.4m)	Item No	Thickness	Weight (Kg/6.4m)
GT1007	1.5	4.1	GT1008	1.5	3.8	GT1011	1.5	7.6
80中柱 FRAME TRASUM 			80边框 COVER 			百叶片 LOUVER 		
Item No	Thickness	Weight (Kg/6.4m)	Item No	Thickness	Weight (Kg/6.4m)	Item No	Thickness	Weight (Kg/6.4m)
GT1012	1.5	8.5	GT1013	1.5	4.2	GT1014	1.4	2.3
Item No	Thickness	Weight (Kg/6.4m)	Item No	Thickness	Weight (Kg/6.4m)	Item No	Thickness	Weight (Kg/6.4m)

ROLLER SHUTTER SERIES/SLIDING NET

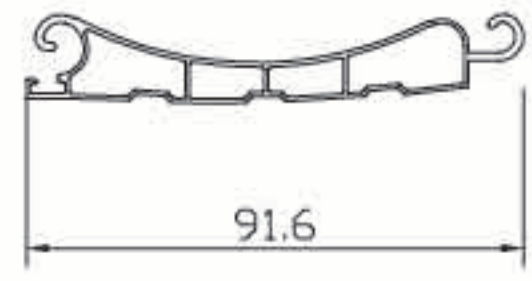
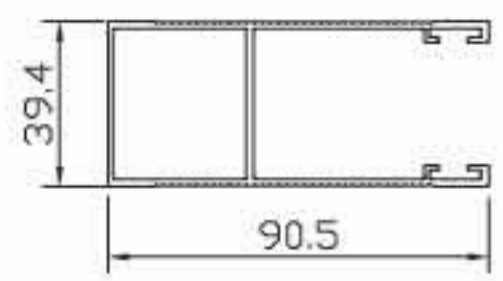
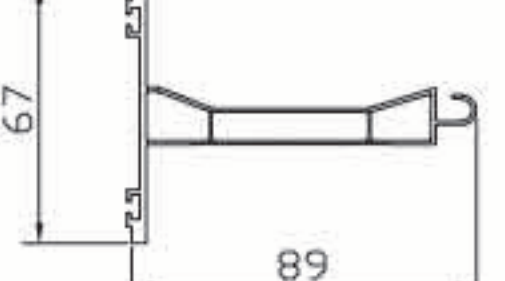
卷闸门片 ROLLER SHUTTER 			边框 OUTER FRAME 			卷闸门下框 ROLLER SHUTTER 		
Item No	Thickness	Weight(Kg/6.4m)	Item No	Thickness	Weight(Kg/6.4m)	Item No	Thickness	Weight(Kg/6.4m)
JZ-01	1.0	4.1	JZ-02	1.8	7.8	JZ-03	1.7	6.3

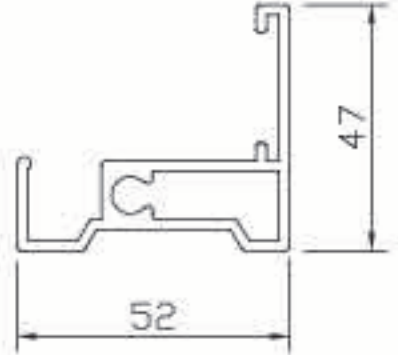
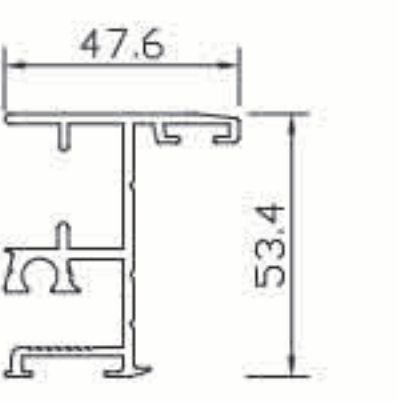
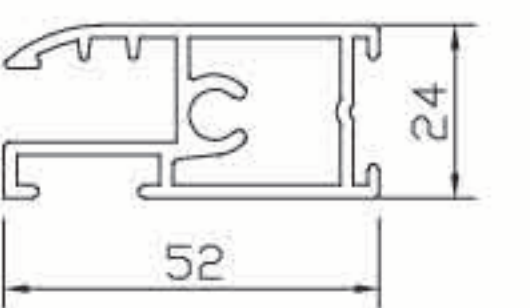
外边框 FRAME 			框料 FRAME 			扇窗 SHUTTER 		
Item No	Thickness	Weight(Kg/6.4m)	Item No	Thickness	Weight(Kg/6.4m)	Item No	Thickness	Weight(Kg/6.4m)
SC-01	1.0	1.68	SC-02	1.0	1.73	SC-03	1.0	1.75

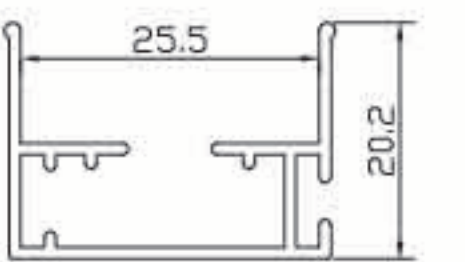
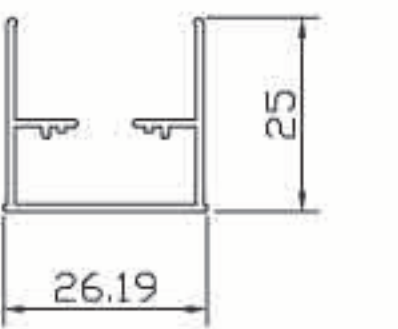
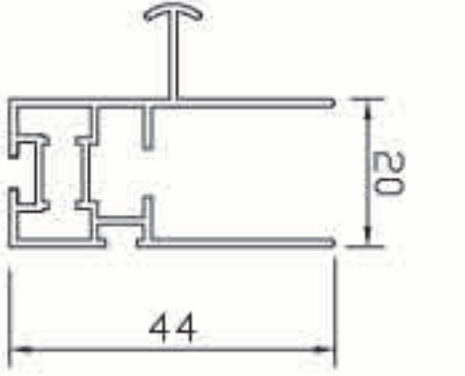
边框 SLIDING NET SECTION 			上下滑 OUTER FRAME 			扇料 SLIDING NET 		
Item No	Thickness	Weight(Kg/6.4m)	Item No	Thickness	Weight(Kg/6.4m)	Item No	Thickness	Weight(Kg/6.4m)
GT20-01	1.0	1.67	GT20-02	1.0	1.67	GT20-03	1.0	3.36

Item No Thickness Weight(Kg/6.4m)			Item No Thickness Weight(Kg/6.4m)			Item No Thickness Weight(Kg/6.4m)		

Item No Thickness Weight(Kg/6.4m)			Item No Thickness Weight(Kg/6.4m)			Item No Thickness Weight(Kg/6.4m)		

FOLDING DOOR

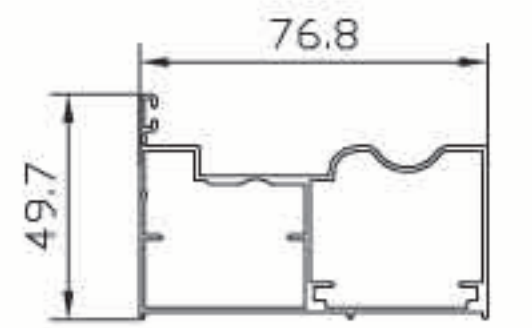
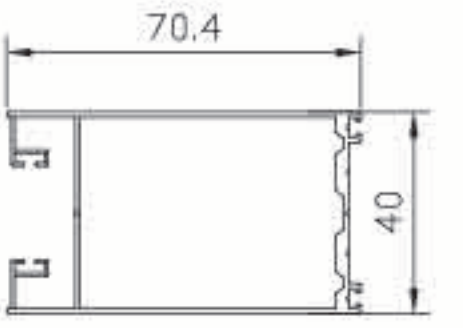
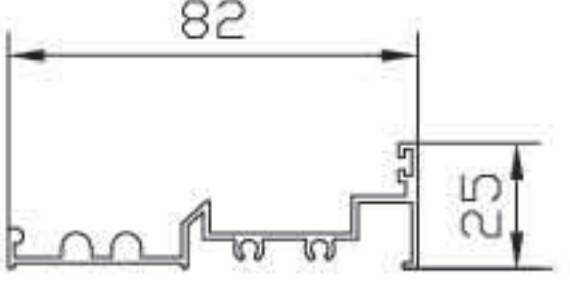
无下轨边框 FRAME 			光企 LOCKING 			低下轨 BOTTOM 		
Item No	Thickness	Weight(Kg/6.4m)	Item No	Thickness	Weight(Kg/6.4m)	Item No	Thickness	Weight(Kg/6.4m)
ZDM-01	1.1	6.6	ZDM-02	1.5	5.3	ZDM-03	1.2	4.6

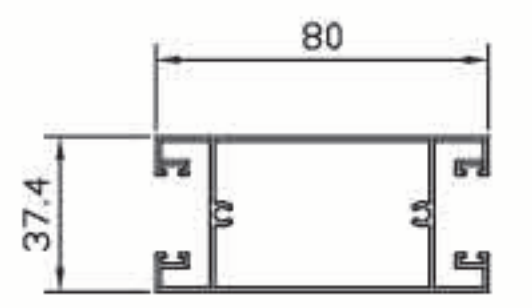
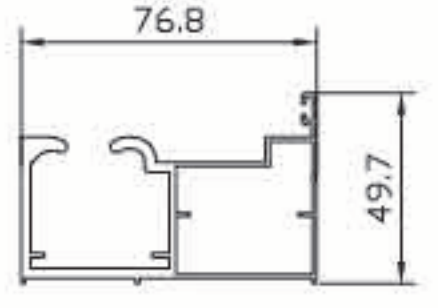
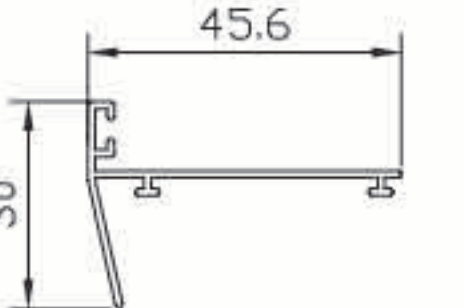
上下方 TOP/BOTTOM-SHUTTER 			大折门吊轨 TOP FRAME 			收口 ADAPTOR 		
Item No	Thickness	Weight(Kg/6.4m)	Item No	Thickness	Weight(Kg/6.4m)	Item No	Thickness	Weight(Kg/6.4m)
ZDM-04	1.1	6.6	ZDM-05	2.5	8.9	ZDM-06	1.0	1.68

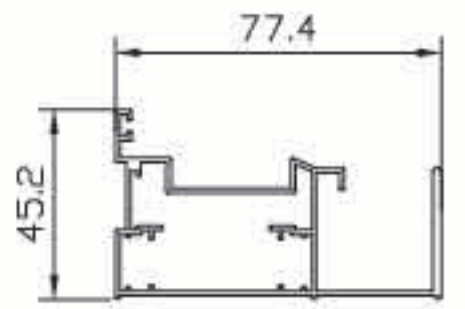
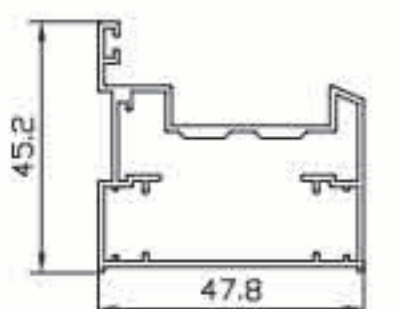
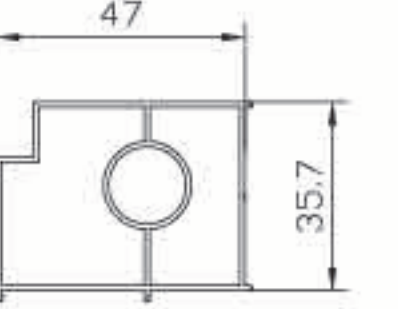
上轨 TOP FRAME 			边框 FRAME 			定位 FIXED POSITION 		
Item No	Thickness	Weight(Kg/6.4m)	Item No	Thickness	Weight(Kg/6.4m)	Item No	Thickness	Weight(Kg/6.4m)
ZDM-07	2.0	6.4	ZDM-08	1.1	4.8	ZDM-09	1.0	4.2

Item No Thickness Weight(Kg/6.4m)			Item No Thickness Weight(Kg/6.4m)			Item No Thickness Weight(Kg/6.4m)		

Item No Thickness Weight(Kg/6.4m)			Item No Thickness Weight(Kg/6.4m)			Item No Thickness Weight(Kg/6.4m)		

FOLDING DOOR

框料
FRAME

Item No	Thickness	Weight (Kg/6.4m)
ZD-01	1.1	3.2

上框料
TOP FRAME

Item No	Thickness	Weight (Kg/6.4m)
ZD-02	1.0	3.3

扇料
SHUTTER

Item No	Thickness	Weight (Kg/6.4m)
ZD-03	1.1	4.2

压板
COVER

Item No	Thickness	Weight (Kg/6.4m)
ZD-04	1.0	1.05

压盖
COVER

Item No	Thickness	Weight (Kg/6.4m)
ZD-05	1.0	0.68

扇料
SHUTTER

Item No	Thickness	Weight (Kg/6.4m)
ZD-06	1.0	2

Item No	Thickness	Weight (Kg/6.4m)

Item No	Thickness	Weight (Kg/6.4m)

Item No	Thickness	Weight (Kg/6.4m)

Item No	Thickness	Weight (Kg/6.4m)

Item No	Thickness	Weight (Kg/6.4m)

Item No	Thickness	Weight (Kg/6.4m)

Item No	Thickness	Weight (Kg/6.4m)

Item No	Thickness	Weight (Kg/6.4m)

Item No	Thickness	Weight (Kg/6.4m)

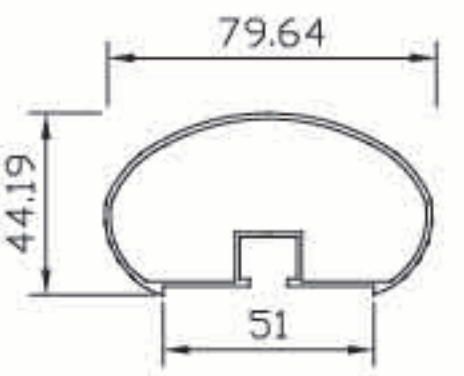
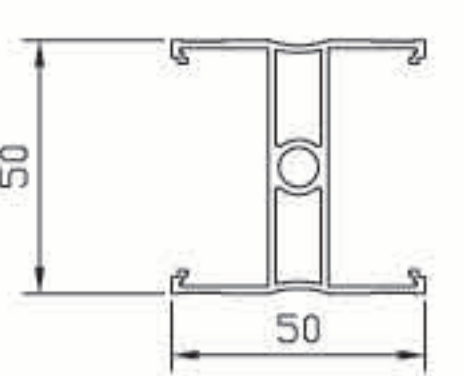
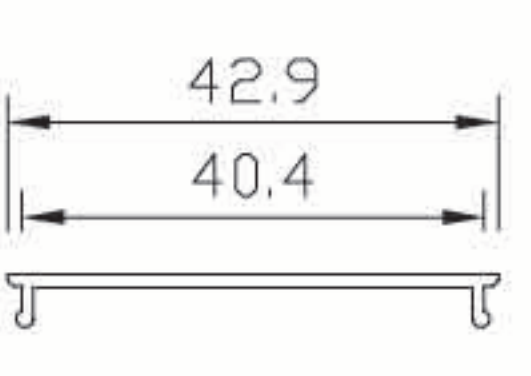
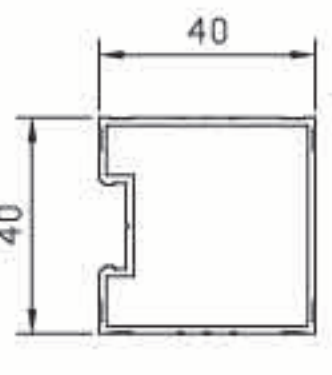
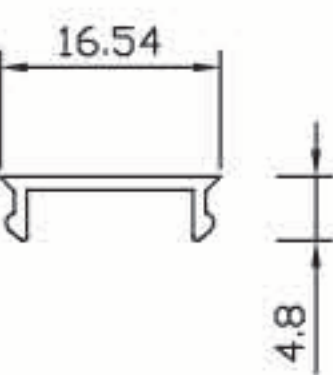
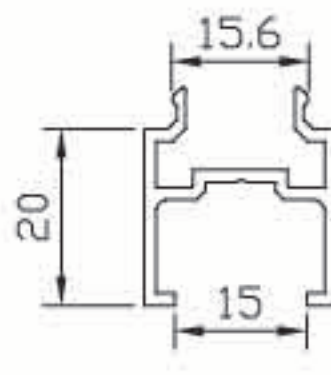
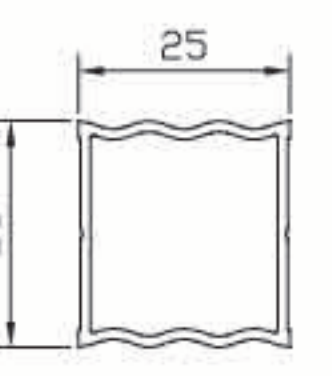
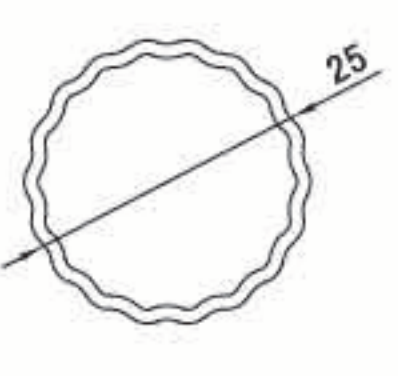
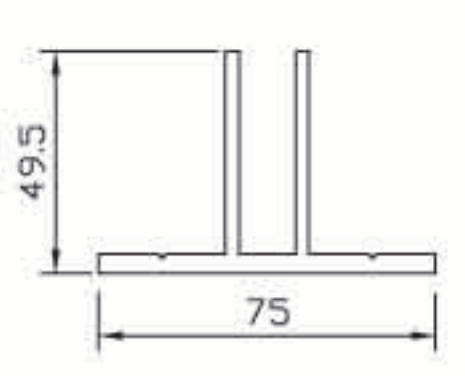

BALCONY RAILING/HANDRAIL PROFILE

扶手面管 HOLLOW SECTION 			扶手中柱 TRANSOME 			中柱盖板 COVER 		
Item No	Thickness	Weight (Kg/6.4m)	Item No	Thickness	Weight (Kg/6.4m)	Item No	Thickness	Weight (Kg/6.4m)
FS-001	1.4	5.6	FS-002	1.5	6.2	FS-003	1.2	1.06
横梁 HOLLOW SECTION 			横梁压板 COVER 			转玻璃框料 FRAME 		
Item No	Thickness	Weight (Kg/6.4m)	Item No	Thickness	Weight (Kg/6.4m)	Item No	Thickness	Weight (Kg/6.4m)
FS-004	1.4	4.1	FS-005	1.0	0.43	FS-006	1.4	2.01
横管 HOLLOW SECTION 			圆管 ROUND PIPE 			中柱固定脚 FIXED POSITION 		
Item No	Thickness	Weight (Kg/6.4m)	Item No	Thickness	Weight (Kg/6.4m)	Item No	Thickness	Weight (Kg/6.4m)
FS-007	1.4	2.15	FS-008	1.2	1.68	FS-009	3.0	11
Item No	Thickness	Weight (Kg/6.4m)	Item No	Thickness	Weight (Kg/6.4m)	Item No	Thickness	Weight (Kg/6.4m)
Item No	Thickness	Weight (Kg/6.4m)	Item No	Thickness	Weight (Kg/6.4m)	Item No	Thickness	Weight (Kg/6.4m)

ALUMINIUM BURGLAR PROOF

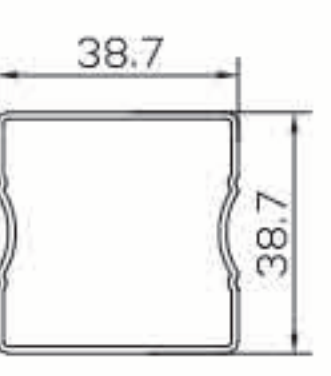
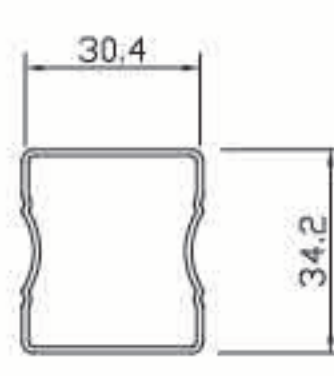
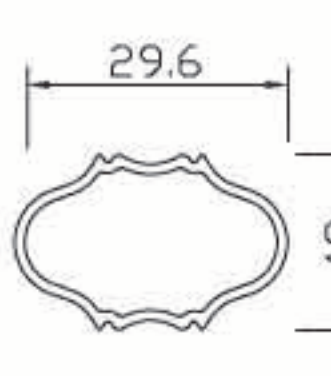
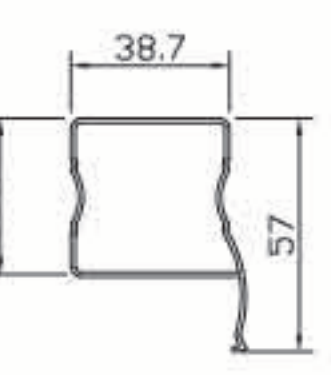
外框 FRAME 			横管 HOLLOW SECTION 			横管 HOLLOW SECTION 		
Item No	Thickness	Weight (Kg/6.4m)	Item No	Thickness	Weight (Kg/6.4m)	Item No	Thickness	Weight (Kg/6.4m)
FD-01	1.1	3.2	FD-02	1.1	2.5	FD-03	1.1	1.55
包边框 FRAME 								
Item No	Thickness	Weight (Kg/6.4m)	Item No	Thickness	Weight (Kg/6.4m)	Item No	Thickness	Weight (Kg/6.4m)
FD-04	1.1	3.5						



CONNECTION SERIES

<p>U槽 U CHANNEL</p>	<p>压板 COVER</p>	<p>收口 ADAPTOR</p>																		
<table border="1"> <thead> <tr> <th>Item No</th> <th>Thickness</th> <th>Weight (Kg/6.4m)</th> </tr> </thead> <tbody> <tr> <td>SH-001</td> <td>1.3</td> <td>0.87</td> </tr> </tbody> </table>	Item No	Thickness	Weight (Kg/6.4m)	SH-001	1.3	0.87	<table border="1"> <thead> <tr> <th>Item No</th> <th>Thickness</th> <th>Weight (Kg/6.4m)</th> </tr> </thead> <tbody> <tr> <td>SH-002</td> <td>1.4</td> <td>4.6</td> </tr> </tbody> </table>	Item No	Thickness	Weight (Kg/6.4m)	SH-002	1.4	4.6	<table border="1"> <thead> <tr> <th>Item No</th> <th>Thickness</th> <th>Weight (Kg/6.4m)</th> </tr> </thead> <tbody> <tr> <td>SH-003</td> <td>1.4</td> <td>1.8</td> </tr> </tbody> </table>	Item No	Thickness	Weight (Kg/6.4m)	SH-003	1.4	1.8
Item No	Thickness	Weight (Kg/6.4m)																		
SH-001	1.3	0.87																		
Item No	Thickness	Weight (Kg/6.4m)																		
SH-002	1.4	4.6																		
Item No	Thickness	Weight (Kg/6.4m)																		
SH-003	1.4	1.8																		
<p>框料 FRAME</p>	<p>插板 PLATE</p>	<p>插板 PLATE</p>																		
<table border="1"> <thead> <tr> <th>Item No</th> <th>Thickness</th> <th>Weight (Kg/6.4m)</th> </tr> </thead> <tbody> <tr> <td>SH-004</td> <td>1.0</td> <td>2</td> </tr> </tbody> </table>	Item No	Thickness	Weight (Kg/6.4m)	SH-004	1.0	2	<table border="1"> <thead> <tr> <th>Item No</th> <th>Thickness</th> <th>Weight (Kg/6.4m)</th> </tr> </thead> <tbody> <tr> <td>P201</td> <td>1.6</td> <td>1.9</td> </tr> </tbody> </table>	Item No	Thickness	Weight (Kg/6.4m)	P201	1.6	1.9	<table border="1"> <thead> <tr> <th>Item No</th> <th>Thickness</th> <th>Weight (Kg/6.4m)</th> </tr> </thead> <tbody> <tr> <td>P202</td> <td>1.6</td> <td>1.8</td> </tr> </tbody> </table>	Item No	Thickness	Weight (Kg/6.4m)	P202	1.6	1.8
Item No	Thickness	Weight (Kg/6.4m)																		
SH-004	1.0	2																		
Item No	Thickness	Weight (Kg/6.4m)																		
P201	1.6	1.9																		
Item No	Thickness	Weight (Kg/6.4m)																		
P202	1.6	1.8																		
<table border="1"> <thead> <tr> <th>Item No</th> <th>Thickness</th> <th>Weight (Kg/6.4m)</th> </tr> </thead> <tbody> <tr> <td></td> <td></td> <td></td> </tr> </tbody> </table>	Item No	Thickness	Weight (Kg/6.4m)				<table border="1"> <thead> <tr> <th>Item No</th> <th>Thickness</th> <th>Weight (Kg/6.4m)</th> </tr> </thead> <tbody> <tr> <td></td> <td></td> <td></td> </tr> </tbody> </table>	Item No	Thickness	Weight (Kg/6.4m)				<table border="1"> <thead> <tr> <th>Item No</th> <th>Thickness</th> <th>Weight (Kg/6.4m)</th> </tr> </thead> <tbody> <tr> <td></td> <td></td> <td></td> </tr> </tbody> </table>	Item No	Thickness	Weight (Kg/6.4m)			
Item No	Thickness	Weight (Kg/6.4m)																		
Item No	Thickness	Weight (Kg/6.4m)																		
Item No	Thickness	Weight (Kg/6.4m)																		
<table border="1"> <thead> <tr> <th>Item No</th> <th>Thickness</th> <th>Weight (Kg/6.4m)</th> </tr> </thead> <tbody> <tr> <td></td> <td></td> <td></td> </tr> </tbody> </table>	Item No	Thickness	Weight (Kg/6.4m)				<table border="1"> <thead> <tr> <th>Item No</th> <th>Thickness</th> <th>Weight (Kg/6.4m)</th> </tr> </thead> <tbody> <tr> <td></td> <td></td> <td></td> </tr> </tbody> </table>	Item No	Thickness	Weight (Kg/6.4m)				<table border="1"> <thead> <tr> <th>Item No</th> <th>Thickness</th> <th>Weight (Kg/6.4m)</th> </tr> </thead> <tbody> <tr> <td></td> <td></td> <td></td> </tr> </tbody> </table>	Item No	Thickness	Weight (Kg/6.4m)			
Item No	Thickness	Weight (Kg/6.4m)																		
Item No	Thickness	Weight (Kg/6.4m)																		
Item No	Thickness	Weight (Kg/6.4m)																		
<table border="1"> <thead> <tr> <th>Item No</th> <th>Thickness</th> <th>Weight (Kg/6.4m)</th> </tr> </thead> <tbody> <tr> <td></td> <td></td> <td></td> </tr> </tbody> </table>	Item No	Thickness	Weight (Kg/6.4m)				<table border="1"> <thead> <tr> <th>Item No</th> <th>Thickness</th> <th>Weight (Kg/6.4m)</th> </tr> </thead> <tbody> <tr> <td></td> <td></td> <td></td> </tr> </tbody> </table>	Item No	Thickness	Weight (Kg/6.4m)				<table border="1"> <thead> <tr> <th>Item No</th> <th>Thickness</th> <th>Weight (Kg/6.4m)</th> </tr> </thead> <tbody> <tr> <td></td> <td></td> <td></td> </tr> </tbody> </table>	Item No	Thickness	Weight (Kg/6.4m)			
Item No	Thickness	Weight (Kg/6.4m)																		
Item No	Thickness	Weight (Kg/6.4m)																		
Item No	Thickness	Weight (Kg/6.4m)																		

CONNECTION SERIES

<p>U槽 U CHANNEL</p>	<p>压座 BUTTER FLY</p>	<p>方压线 BEADING</p>																					
<table border="1"> <thead> <tr> <th>Item No</th> <th>Thickness</th> <th>Weight (Kg/6.4m)</th> </tr> </thead> <tbody> <tr> <td>10X10</td> <td>1.0</td> <td>0.6</td> </tr> </tbody> </table>	Item No	Thickness	Weight (Kg/6.4m)	10X10	1.0	0.6	<table border="1"> <thead> <tr> <th>Item No</th> <th>Thickness</th> <th>Weight (Kg/6.4m)</th> </tr> </thead> <tbody> <tr> <td>01-012</td> <td>1.5</td> <td>2.8</td> </tr> </tbody> </table>	Item No	Thickness	Weight (Kg/6.4m)	01-012	1.5	2.8	<table border="1"> <thead> <tr> <th>Item No</th> <th>Thickness</th> <th>Weight (Kg/6.4m)</th> </tr> </thead> <tbody> <tr> <td>46-6</td> <td>0.8</td> <td>0.9</td> </tr> </tbody> </table>	Item No	Thickness	Weight (Kg/6.4m)	46-6	0.8	0.9			
Item No	Thickness	Weight (Kg/6.4m)																					
10X10	1.0	0.6																					
Item No	Thickness	Weight (Kg/6.4m)																					
01-012	1.5	2.8																					
Item No	Thickness	Weight (Kg/6.4m)																					
46-6	0.8	0.9																					
<p>方压线 BEADING</p>	<p>100扣板 PANNEL</p>	<p>110扣板 PANNEL</p>																					
<table border="1"> <thead> <tr> <th>Item No</th> <th>Thickness</th> <th>Weight (Kg/6.4m)</th> </tr> </thead> <tbody> <tr> <td>01-013</td> <td>1.5</td> <td>1.4</td> </tr> </tbody> </table>	Item No	Thickness	Weight (Kg/6.4m)	01-013	1.5	1.4	<table border="1"> <thead> <tr> <th>Item No</th> <th>Thickness</th> <th>Weight (Kg/6.4m)</th> </tr> </thead> <tbody> <tr> <td>100X8</td> <td>1.0</td> <td>4.2</td> </tr> <tr> <td></td> <td>0.7</td> <td>2.95</td> </tr> </tbody> </table>	Item No	Thickness	Weight (Kg/6.4m)	100X8	1.0	4.2		0.7	2.95	<table border="1"> <thead> <tr> <th>Item No</th> <th>Thickness</th> <th>Weight (Kg/6.4m)</th> </tr> </thead> <tbody> <tr> <td>115X8.5</td> <td>1.2</td> <td>5.4</td> </tr> </tbody> </table>	Item No	Thickness	Weight (Kg/6.4m)	115X8.5	1.2	5.4
Item No	Thickness	Weight (Kg/6.4m)																					
01-013	1.5	1.4																					
Item No	Thickness	Weight (Kg/6.4m)																					
100X8	1.0	4.2																					
	0.7	2.95																					
Item No	Thickness	Weight (Kg/6.4m)																					
115X8.5	1.2	5.4																					
<p>压座 BUTTER FLY</p>	<p>斜压线 BEADING</p>	<p>百叶片B LOOVER</p>																					
<table border="1"> <thead> <tr> <th>Item No</th> <th>Thickness</th> <th>Weight (Kg/6.4m)</th> </tr> </thead> <tbody> <tr> <td>25压座</td> <td>1.0</td> <td>0.99</td> </tr> </tbody> </table>	Item No	Thickness	Weight (Kg/6.4m)	25压座	1.0	0.99	<table border="1"> <thead> <tr> <th>Item No</th> <th>Thickness</th> <th>Weight (Kg/6.4m)</th> </tr> </thead> <tbody> <tr> <td>25压线</td> <td>1.0</td> <td>0.85</td> </tr> </tbody> </table>	Item No	Thickness	Weight (Kg/6.4m)	25压线	1.0	0.85	<table border="1"> <thead> <tr> <th>Item No</th> <th>Thickness</th> <th>Weight (Kg/6.4m)</th> </tr> </thead> <tbody> <tr> <td>01-150</td> <td>1.2</td> <td>2.3</td> </tr> </tbody> </table>	Item No	Thickness	Weight (Kg/6.4m)	01-150	1.2	2.3			
Item No	Thickness	Weight (Kg/6.4m)																					
25压座	1.0	0.99																					
Item No	Thickness	Weight (Kg/6.4m)																					
25压线	1.0	0.85																					
Item No	Thickness	Weight (Kg/6.4m)																					
01-150	1.2	2.3																					
<p>门下框 KICK PLATE</p>	<p>压座 BUTTER FLY</p>	<p>斜压线 BEADING</p>																					
<table border="1"> <thead> <tr> <th>Item No</th> <th>Thickness</th> <th>Weight (Kg/6.4m)</th> </tr> </thead> <tbody> <tr> <td>01-014</td> <td>4</td> <td>6.8</td> </tr> </tbody> </table>	Item No	Thickness	Weight (Kg/6.4m)	01-014	4	6.8	<table border="1"> <thead> <tr> <th>Item No</th> <th>Thickness</th> <th>Weight (Kg/6.4m)</th> </tr> </thead> <tbody> <tr> <td>3808A</td> <td>1.0</td> <td>1.1</td> </tr> </tbody> </table>	Item No	Thickness	Weight (Kg/6.4m)	3808A	1.0	1.1	<table border="1"> <thead> <tr> <th>Item No</th> <th>Thickness</th> <th>Weight (Kg/6.4m)</th> </tr> </thead> <tbody> <tr> <td>38B15</td> <td>1.0</td> <td>1</td> </tr> </tbody> </table>	Item No	Thickness	Weight (Kg/6.4m)	38B15	1.0	1			
Item No	Thickness	Weight (Kg/6.4m)																					
01-014	4	6.8																					
Item No	Thickness	Weight (Kg/6.4m)																					
3808A	1.0	1.1																					
Item No	Thickness	Weight (Kg/6.4m)																					
38B15	1.0	1																					
<table border="1"> <thead> <tr> <th>Item No</th> <th>Thickness</th> <th>Weight (Kg/6.4m)</th> </tr> </thead> <tbody> <tr> <td></td> <td></td> <td></td> </tr> </tbody> </table>	Item No	Thickness	Weight (Kg/6.4m)				<table border="1"> <thead> <tr> <th>Item No</th> <th>Thickness</th> <th>Weight (Kg/6.4m)</th> </tr> </thead> <tbody> <tr> <td></td> <td></td> <td></td> </tr> </tbody> </table>	Item No	Thickness	Weight (Kg/6.4m)				<table border="1"> <thead> <tr> <th>Item No</th> <th>Thickness</th> <th>Weight (Kg/6.4m)</th> </tr> </thead> <tbody> <tr> <td></td> <td></td> <td></td> </tr> </tbody> </table>	Item No	Thickness	Weight (Kg/6.4m)						
Item No	Thickness	Weight (Kg/6.4m)																					
Item No	Thickness	Weight (Kg/6.4m)																					
Item No	Thickness	Weight (Kg/6.4m)																					



HOLLOW SECTION SERIES

10044方管
HOLLOW SECTION

Item No	Thickness	Weight (Kg/6.4m)
10044	2.0	10.4
	1.2	6.2
	1.5	7.3

10025方管
HOLLOW SECTION

Item No	Thickness	Weight (Kg/6.4m)
10025	1.4	6.4

8040方管
HOLLOW SECTION

Item No	Thickness	Weight (Kg/6.4m)
8040	1.5	6.7
	1.2	4.9

7644方管
HOLLOW SECTION

Item No	Thickness	Weight (Kg/6.4m)
7644	2.0	8.5
	1.2	4.9

7625方管
HOLLOW SECTION

Item No	Thickness	Weight (Kg/6.4m)
7625	1.4	5.2

5025方管
HOLLOW SECTION

Item No	Thickness	Weight (Kg/6.4m)
5025	1.2	3.1

9025方管
HOLLOW SECTION

Item No	Thickness	Weight (Kg/6.4m)
9025	1.4	5.8

3825方管
HOLLOW SECTION

Item No	Thickness	Weight (Kg/6.4m)
3825	1.2	2.5

25方管
HOLLOW SECTION

Item No	Thickness	Weight (Kg/6.4m)
2525	1.2	2.1

100方管
HOLLOW SECTION

Item No	Thickness	Weight (Kg/6.4m)
100100	2.3	16.1

40方管
HOLLOW SECTION

Item No	Thickness	Weight (Kg/6.4m)
4040	1.5	4.3

6040方管
HOLLOW SECTION

Item No	Thickness	Weight (Kg/6.4m)
6040	1.5	5.5

Item No	Thickness	Weight (Kg/6.4m)

Item No	Thickness	Weight (Kg/6.4m)

Item No	Thickness	Weight (Kg/6.4m)

HOLLOW SECTION SERIES

9050方管
HOLLOW SECTION

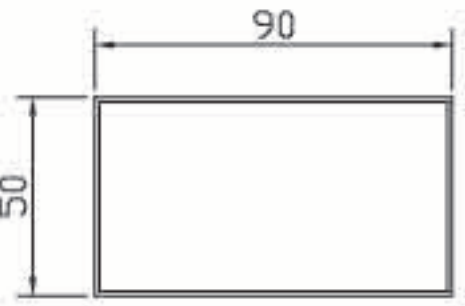

Item No	Thickness	Weight (Kg/6.4m)
9050	1.2	6.2

2020方管
HOLLOW SECTION

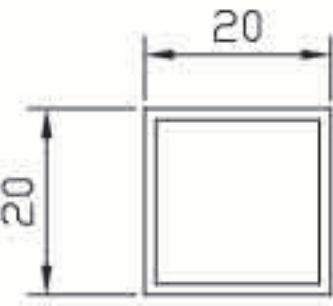

Item No	Thickness	Weight (Kg/6.4m)
2020	1.2	1.64

80方管
HOLLOW SECTION

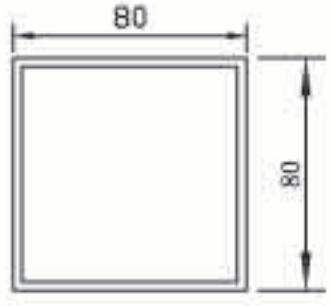

Item No	Thickness	Weight (Kg/6.4m)
8080	2.0	11.1

9040方管
HOLLOW SECTION

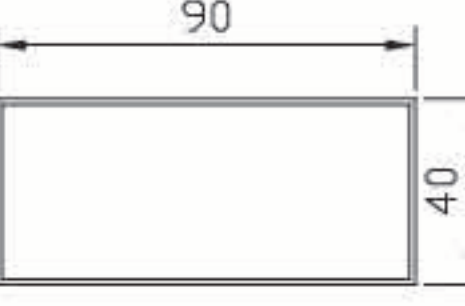

Item No	Thickness	Weight (Kg/6.4m)
9040	1.2	5.5

15050方管
HOLLOW SECTION

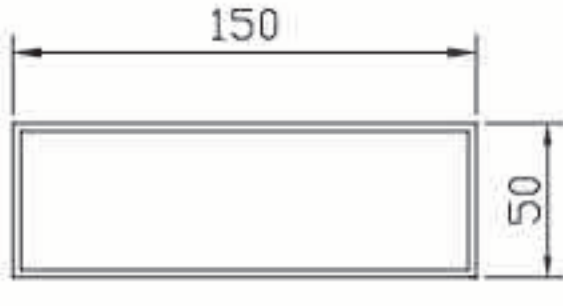

Item No	Thickness	Weight (Kg/4m)
15050	2.6	11.5

15050方管
HOLLOW SECTION

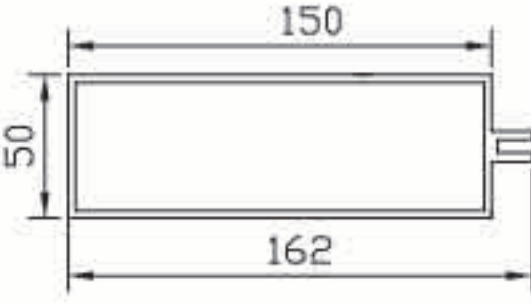

Item No	Thickness	Weight (Kg/4m)
15050A	2.6	12

圆管
ROUND PIPE

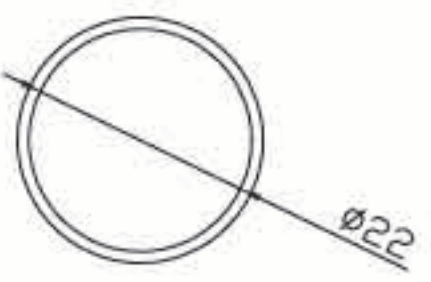

Item No	Thickness	Weight (Kg/6.4m)
GT08-12	1.0	1.2

圆管
ROUND PIPE

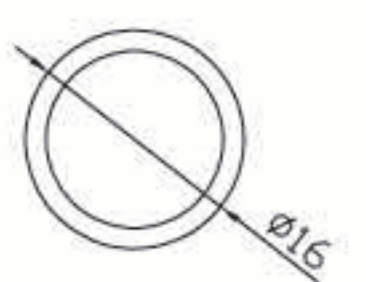

Item No	Thickness	Weight (Kg/6.4m)
GT08-12A	1.5	1.27

U槽
U CHANNEL

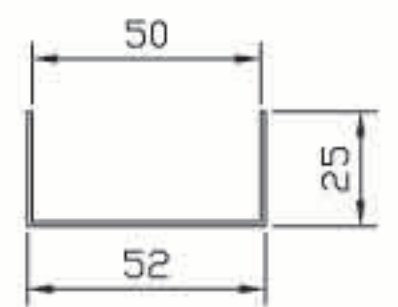

Item No	Thickness	Weight (Kg/6.4m)
50X25C	1.0	1.8

7525U槽
U CHANNEL

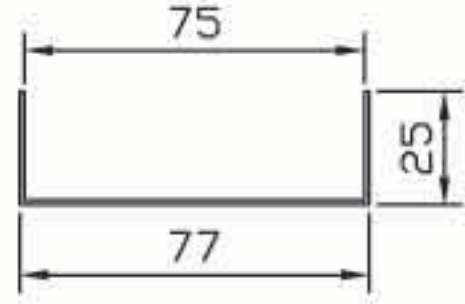

9040方管
HOLLOW SECTION

Item No	Thickness	Weight (Kg/6.4m)
75X25	1.0	2.2

4020U槽
U CHANNEL

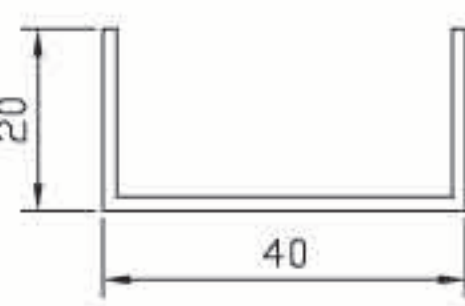

Item No	Thickness	Weight (Kg/6.4m)
40X20	1.5	2.1

10025U槽
U CHANNEL

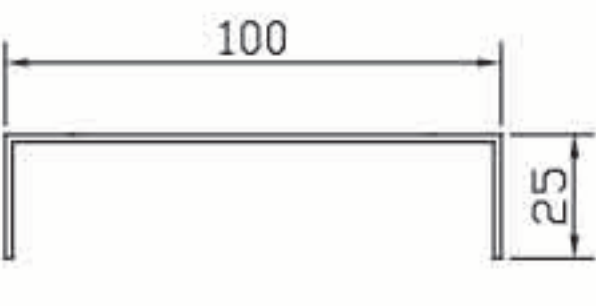

Item No	Thickness	Weight (Kg/6.4m)
GT9012	1.5	4.1

1044方管
HOLLOW SECTION

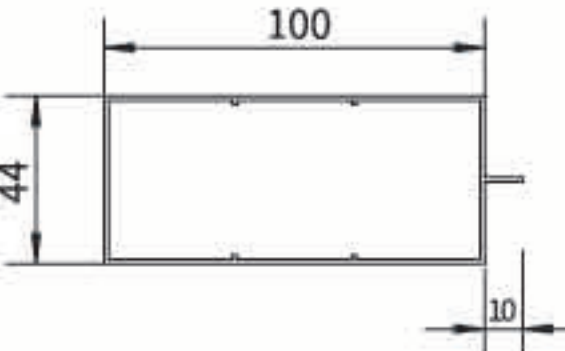

Item No	Thickness	Weight (Kg/6.4m)
10044C	1.2	6.5

8040C方管
HOLLOW SECTION

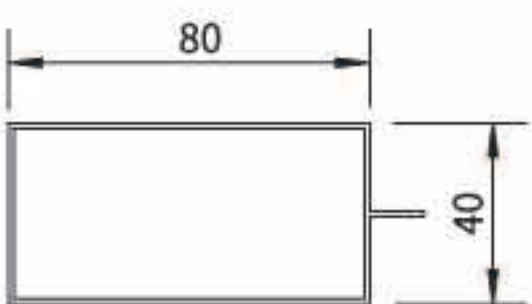

Item No	Thickness	Weight (Kg/6.4m)
8040C	1.2	5.4

24x16方管
HOLLOW SECTION

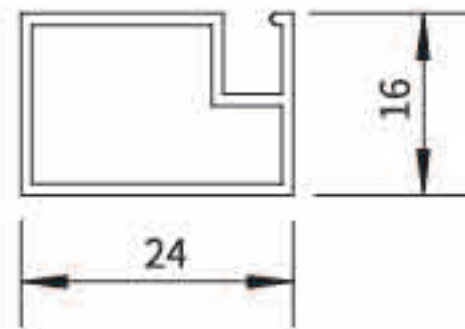

Item No	Thickness	Weight (Kg/6.4m)
24x16	1.0	1.5

ANGEL SERIES

3020角铝
ANGLE

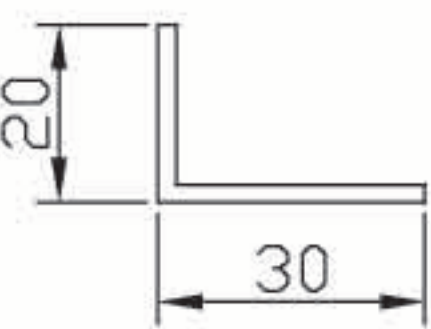

Item No	Thickness	Weight (Kg/6.4m)
20X30	2.0	1.8

20角铝
20X20

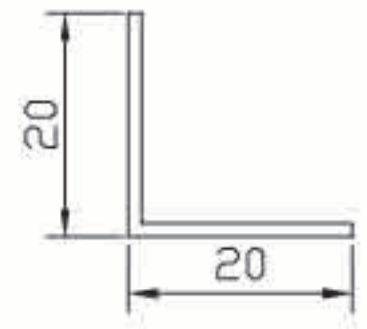

Item No	Thickness	Weight (Kg/6.4m)
20X20	1.2	0.9

40角铝
ANGLE

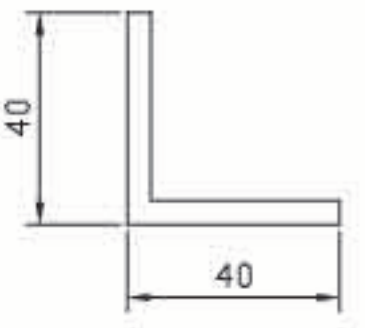

Item No	Thickness	Weight (Kg/6.4m)
40X40	4.5	6.2

15角铝
ANGLE

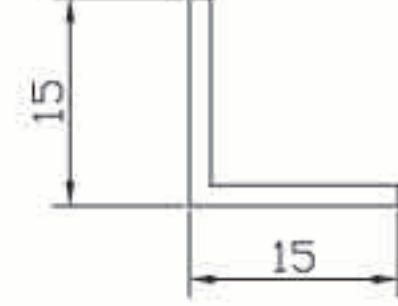

Item No	Thickness	Weight (Kg/6.4m)
15X15	1.5	0.8

25角铝
ANGLE

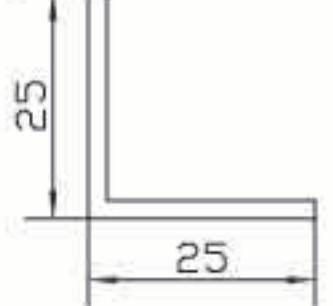

Item No	Thickness	Weight (Kg/6.4m)
25X25	2.0	1.8

50角铝
50X50

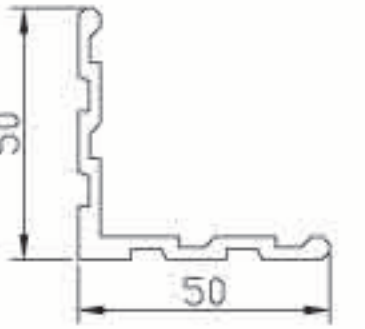

Item No	Thickness	Weight (Kg/6.4m)
50X50	2.4	6

38角铝
ANGLE

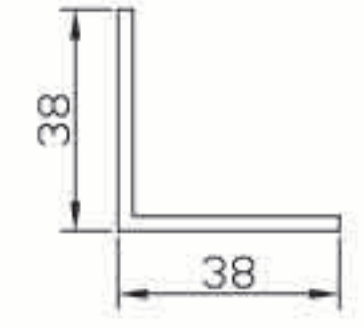

Item No	Thickness	Weight (Kg/6.4m)
38X38	2.5	3.3

5025角铝
ANGLE

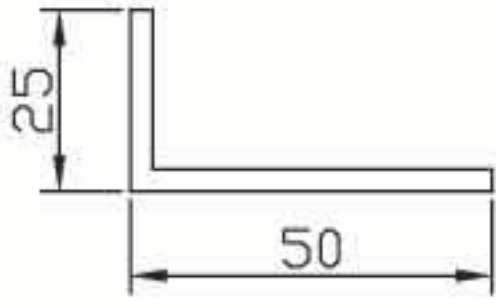

Item No	Thickness	Weight (Kg/6.4m)
50X25	3	3.8

10050角铝
100X50

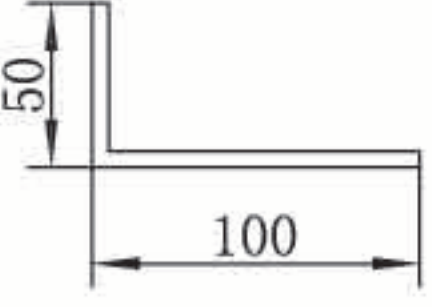

Item No	Thickness	Weight (Kg/6.4m)
100X50	5.0	13

30T铝
T SECTION

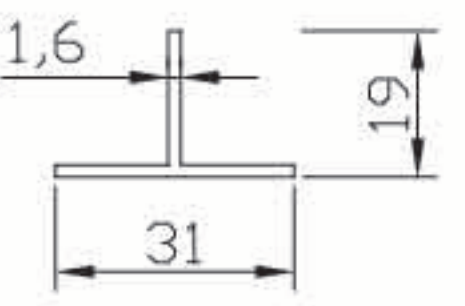

Item No	Thickness	Weight (Kg/6.4m)
211-003	1.6	1.4

40铝条
FLAT BAR

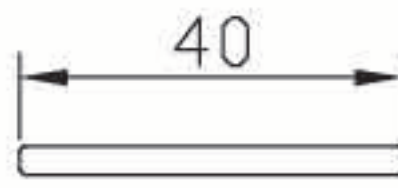

Item No	Thickness	Weight (Kg/6.4m)
40X3	3	2.0

60角铝
ANGLE

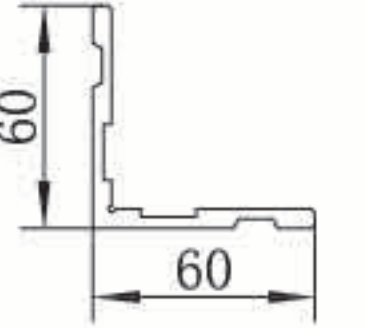

Item No	Thickness	Weight (Kg/6.4m)
60X60	5.2	8.5

Item No	Thickness	Weight (Kg/6.4m)

Item No	Thickness	Weight (Kg/6.4m)

Item No	Thickness	Weight (Kg/6.4m)

CAL SERIES

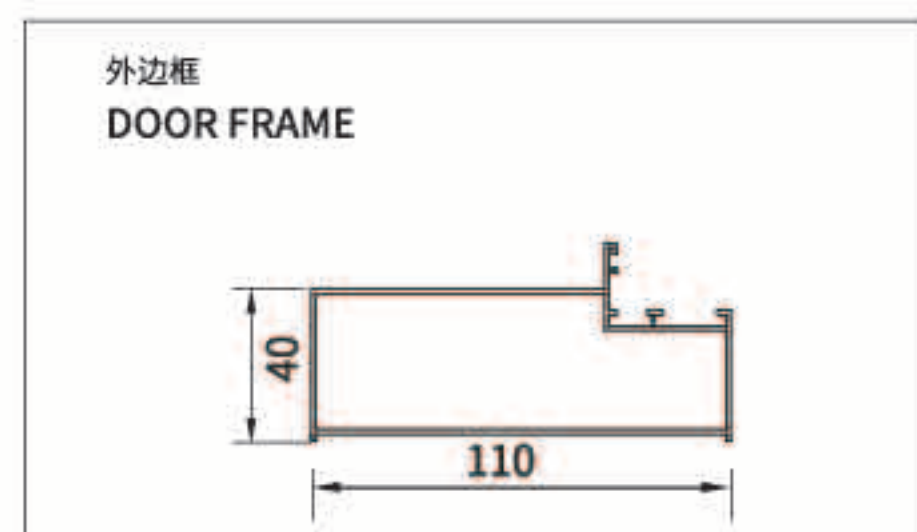

Item No	Thickness	Weight (Kg/6.4m)
CAL-E 011	1.2	6.88

门扇料
DOOR SHUTTER/OUT

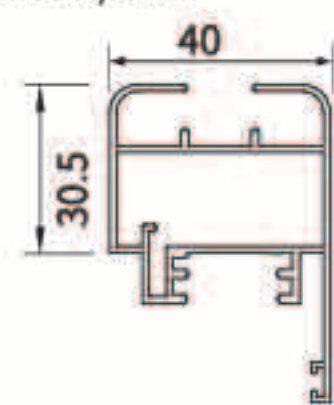

Item No	Thickness	Weight (Kg/6.4m)
CAL-E 012	1.2	5.18

三轨边窗
VENT TRANSOME

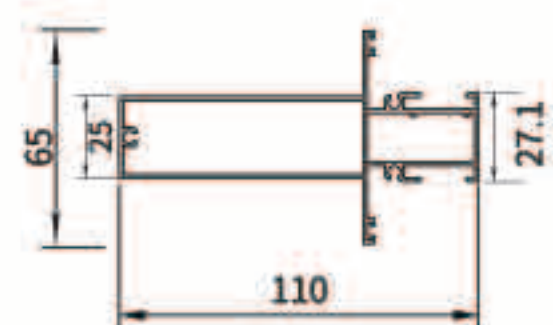

Item No	Thickness	Weight (Kg/6.4m)
CAL-E 013	1.2	8.13

压座
BUTTER FLY

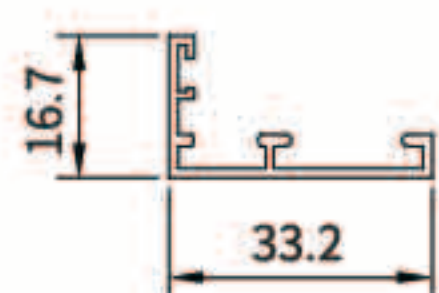

Item No	Thickness	Weight (Kg/6.4m)
CAL-E 014	1.2	1.51

外边框
DOOR FRAME

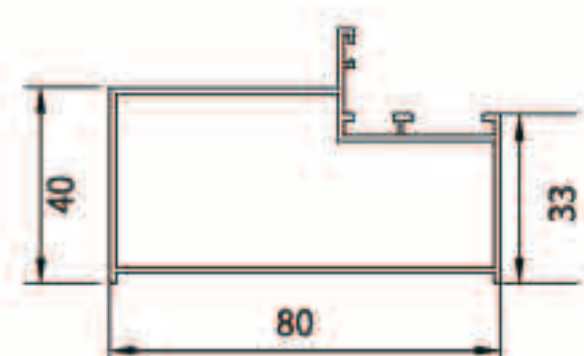

Item No	Thickness	Weight (Kg/6.4m)
CAL-E 015	1.3	6.08

二轨中柱
TRANSOME

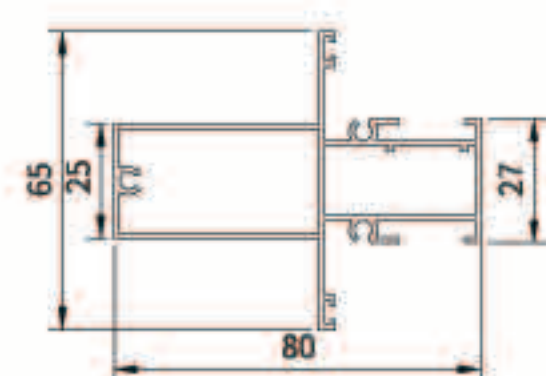

Item No	Thickness	Weight (Kg/6.4m)
CAL-E 016	1.2	6.85

收口
ADAPTOR

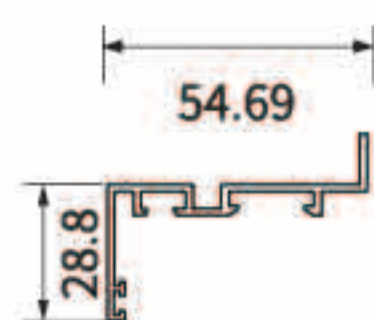

Item No	Thickness	Weight (Kg/6.4m)
CAL-E 017	1.5	3.2

扇料
SHUTTER

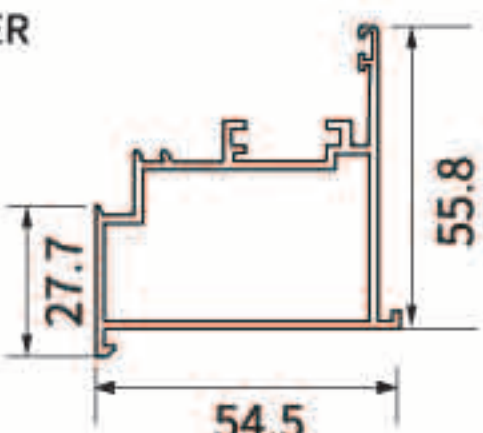

Item No	Thickness	Weight (Kg/6.4m)
CAL-E 018	1.5	6.14

滑杆
FLAT-BAR

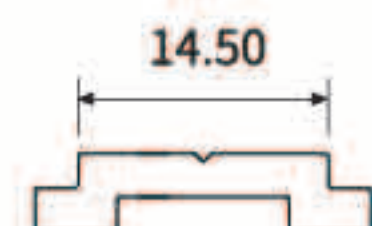

Item No	Thickness	Weight (Kg/6.4m)
CAL-E 019	2.5	1

外边框
FRAME

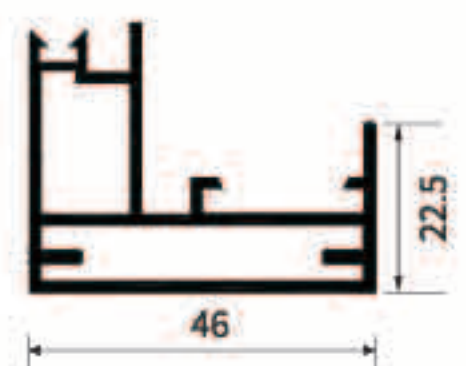

Item No	Thickness	Weight (Kg/6.4m)
CAL-E 005	1.5	5.6

横梁
BOTTOM RAIL

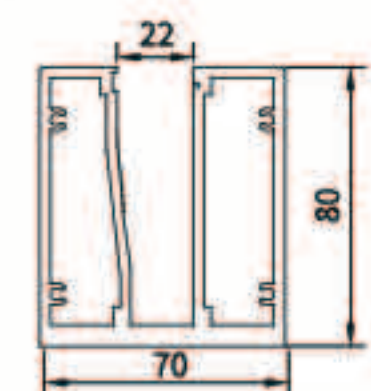

Item No	Thickness	Weight (Kg/6.4m)
CAL-E 020	6	12.5

扶手面管
TOP RAIL

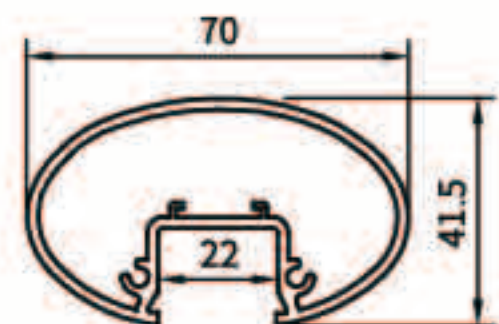

Item No	Thickness	Weight (Kg/6.4m)
CAL-E 021	2	8.08

横梁
BOTTOM RAIL

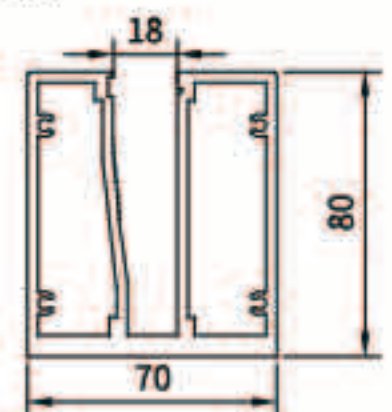

Item No	Thickness	Weight (Kg/6.4m)
CAL-E 022	6	12.6

扶手面管
TOP RAIL (01-142) (2001-10)

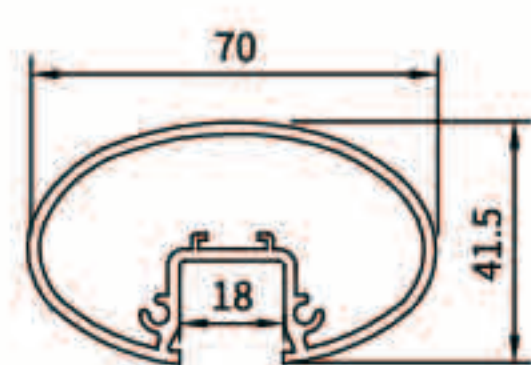

Item No	Thickness	Weight (Kg/6.4m)
CAL-E 023	2	8.05

收口
ADAPTOR

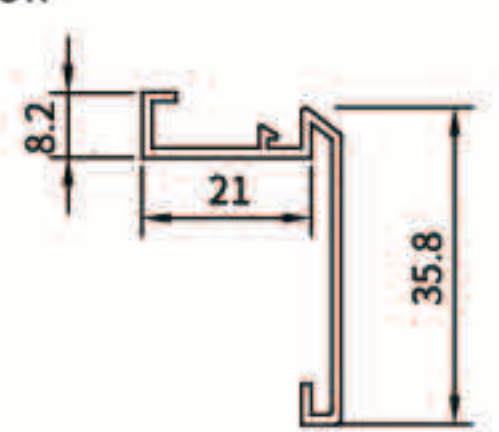

Item No	Thickness	Weight (Kg/6.4m)
CAL-E 024	1.2	1.9

CAL SERIES

收口
ADAPTOR

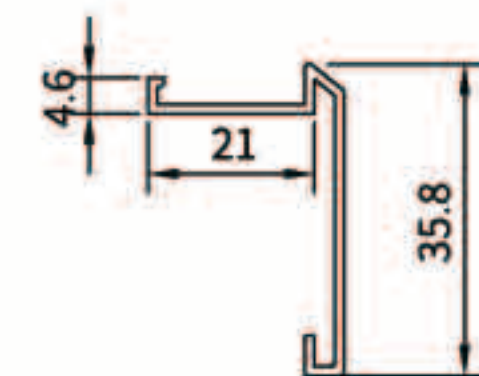

Item No	Thickness	Weight (Kg/6.4m)
CAL-E 025	1.2	1.7

圆管
ROUND PIPE



Item No	Thickness	Weight (Kg/6.4m)
CAL01-S1	1.0	0.6

椭圆管
BEADING

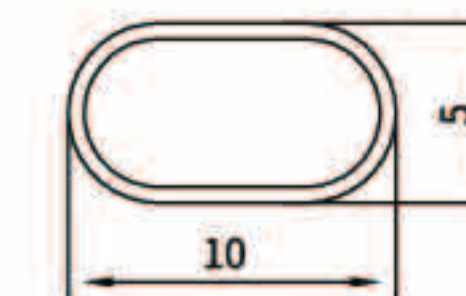

Item No	Thickness	Weight (Kg/6.4m)
CAL01-005	5	0.79

横梁
CURTAIN WALL FRAME-HORIZONTAL

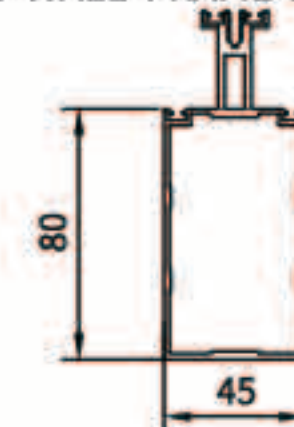

Item No	Thickness	Weight (Kg/6.4m)
CAL01-001	2.0	11.9

边梁
CURTAIN WALL FRAME-HORIZONTAL



Item No	Thickness	Weight (Kg/6.4m)
CAL01-002	1.5	8.9

副梁
CURTAIN WALL FRAME-HORIZONTAL

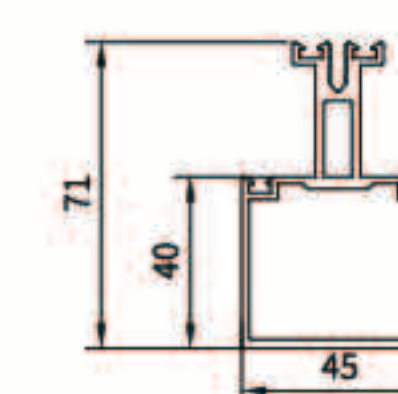

Item No	Thickness	Weight (Kg/6.4m)
CAL01-003	2.0	9.1

横梁
CURTAIN WALL FRAME-HORIZONTAL

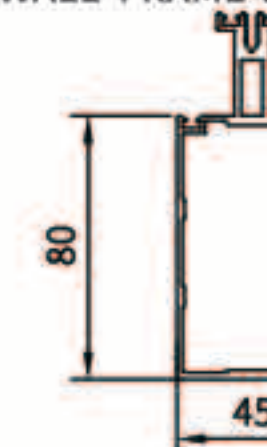

Item No	Thickness	Weight (Kg/6.4m)
CAL01-001A	2.5	12.6

边料
BEADING



Item No	Thickness	Weight (Kg/6.4m)
CAL01-004	1.4	3.2

横梁
CURTAIN WALL FRAME-HORIZONTAL

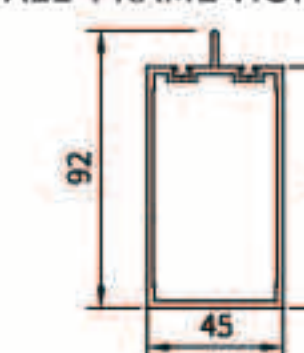

Item No	Thickness	Weight (Kg/6.4m)
CAL-E001	2.5	10.6

副梁
CURTAIN WALL FRAME-HORIZONTAL

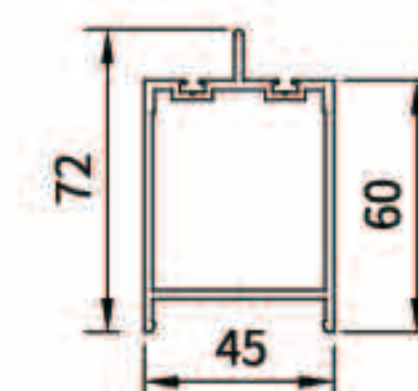

Item No	Thickness	Weight (Kg/6.4m)
CAL-E002	2.5	8.7

压条
TRANSOME

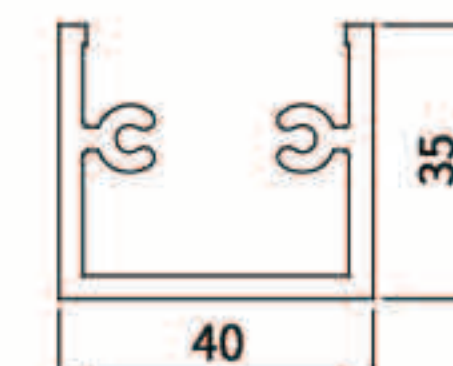

Item No	Thickness	Weight (Kg/6.4m)
CAL-E003	3.0	7.4

盖板
TOP COVER

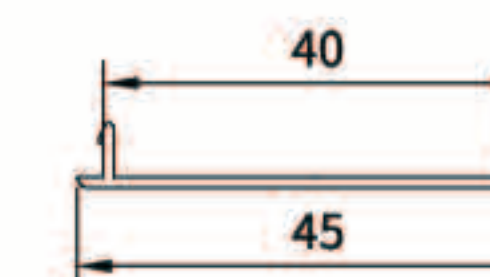

Item No	Thickness	Weight (Kg/6.4m)
CAL-E004	1.0	1.03

压条
TRANSOME

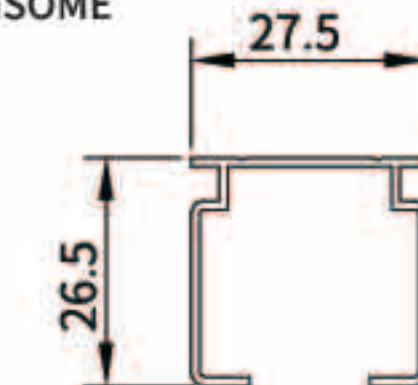

Item No	Thickness	Weight (Kg/6.4m)
DG2726	1.0	1.75

花管
BEADING (01-142) (2001-10)



Item No	Thickness	Weight (Kg/6.4m)
S7	1.0	0.5

包边
TOP VENT

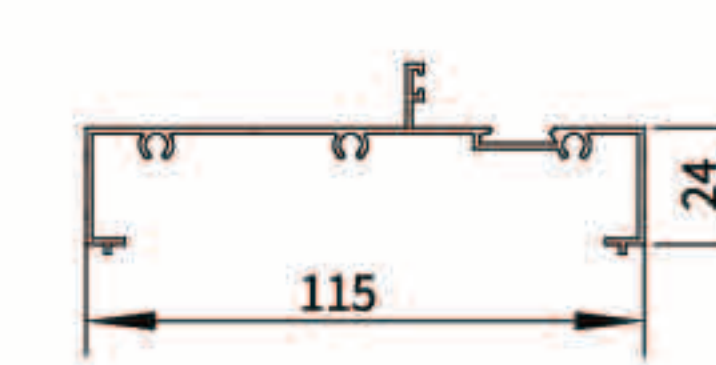

Item No	Thickness	Weight (Kg/6.4m)
CAL-90-07A	1.2	5.2



RAL/1015



RAL/2010



RAL/3003



RAL/5005



RAL/5021



RAL/6005



RAL/7000



RAL/7008



RAL/7016



RAL/7022



RAL/7033



RAL/7043



RAL/7047



RAL/8014



RAL/8017



RAL/8024



RAL/9003



RAL/9005



RAL/9010

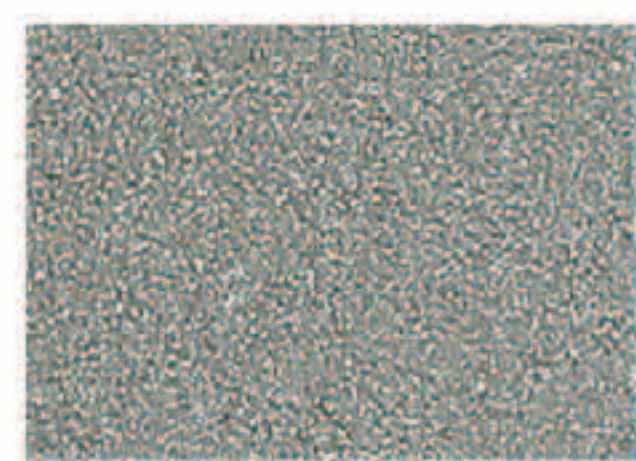

3038



3128

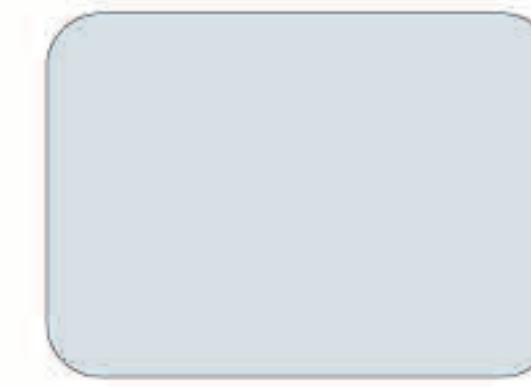

A1



A5



A4



A8



A10



D1



D5



D4



D8



D10

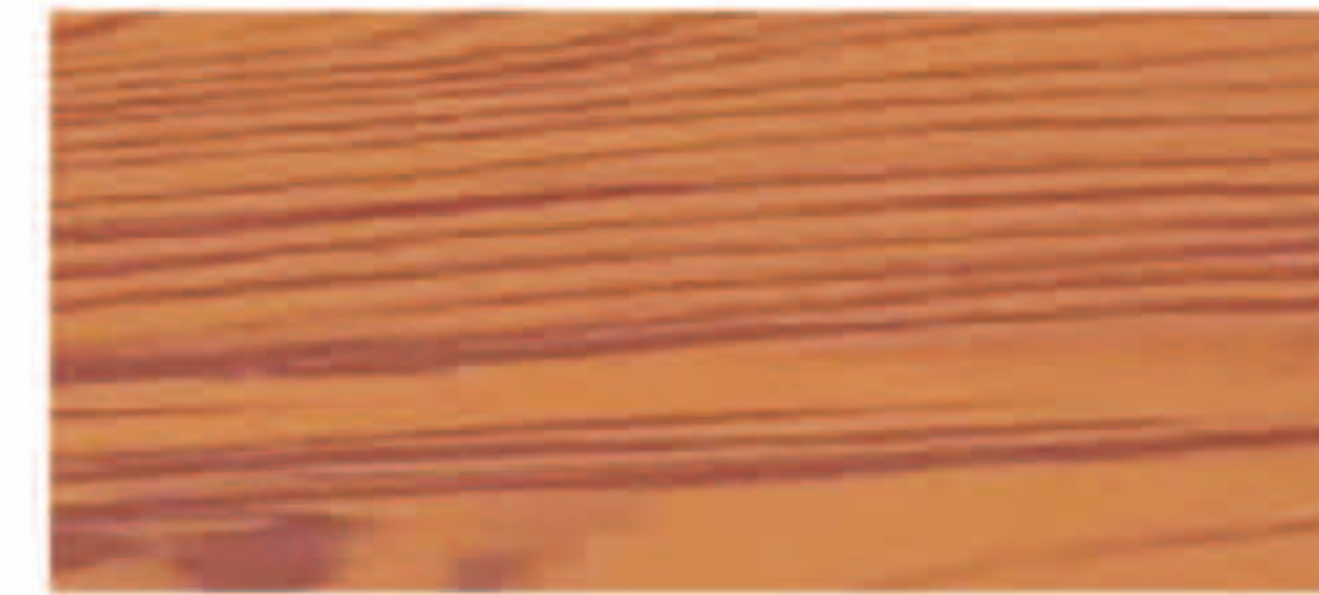

7241



7240



7241-1



7240-1

NOTE: KINDLY FOLLOW COLOURS ON PHYSICAL SAMPLE COLOUR CHART



**AL01-R
Metallic Silver**

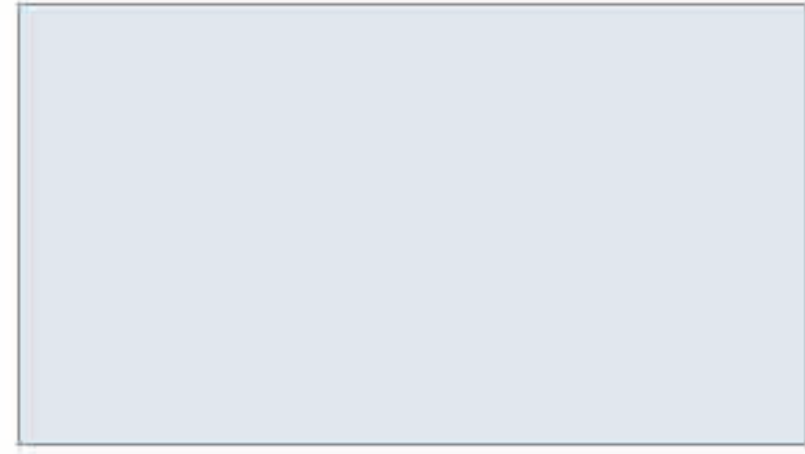

**AL03-R
Pure White**



**AL04-R
Apricot**



**AL07-R
Champagne Silver**



**AL10-R
Dark Blue**



**AL15-R
Red**

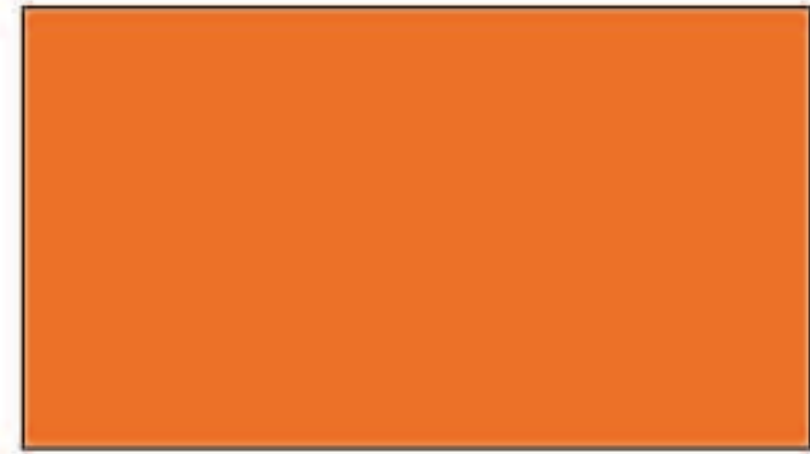

**AL17-R
Orange**



**AL18-R
Basalt Grey**



**AL20-R
Yellow**



**AL24-R
Black**



**AL26-R
Clay Brown**



**AL27-R
Metallic Gold**

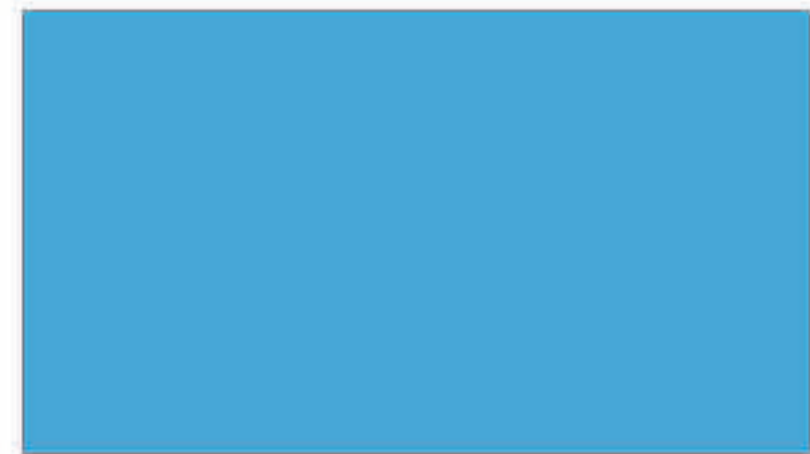

**AL29-R
Lake Blue**



**AL32-R
Black Silver**



**AL37-R
Brown**



**PA-03
Mirror Silver**



**PA-05
Mirror Gold**



PWB0109-E



PW0716-E

NOTE: KINDLY FOLLOW COLOURS ON PHYSICAL SAMPLE COLOUR CHART

ACCESSORIES

Picture			Picture			Picture		
								
Item No	Name		Item No	Name		Item No	Name	
GT02	7*5毛条	300米每卷	GT02A	8*6毛条		GT02B	10.5*7毛条	
Picture			Picture			Picture		
								
Item No	Name		Item No	Name		Item No	Name	
GT04	合页		GT05	合页		GT06	4*12螺丝	1200/kg
Picture			Picture			Picture		
								
Item No	Name		Item No	Name		Item No	Name	
GT07	4*20螺丝	790/kg	GT07A	4*30螺丝		GT08	4*50螺丝	350/kg
Picture			Picture			Picture		
								
Item No	Name		Item No	Name		Item No	Name	
GT09	5*40螺丝	290/kg	GT10	5*80螺丝	170/kg	GT11	10*10双面胶	100根/捆
Picture			Picture			Picture		
								
Item No	Name		Item No	Name		Item No	Name	
GT12	5*10双面胶	200根/捆	GT13	十字螺丝刀		GT14	十字批头	

ACCESSORIES

Picture			Picture			Picture		
								
Item No	Name		Item No	Name		Item No	Name	
GT15	地弹簧		GT17	双向月牙锁		GT18	银色月牙锁	
Picture			Picture			Picture		
								
Item No	Name		Item No	Name		Item No	Name	
GT19	2001上下付档	100个每包	GT21	2001古铜轮		GT22	2001内沙角	100个每包
Picture			Picture			Picture		
								
Item No	Name		Item No	Name		Item No	Name	
GT23	2001外沙角		GT25	3000AA优	10Kgrollers	GT26	76窗轮子	
Picture			Picture			Picture		
								
Item No	Name		Item No	Name		Item No	Name	
GT27	76纱窗轮子		GT28	88纱窗轮子		GT29	88轮子	
Picture			Picture			Picture		
								
Item No	Name		Item No	Name		Item No	Name	
GT30	1.2米灰色纱网	每卷30米	GT31	1米灰色纱网	每卷30米	GT32	门把手	

ACCESSORIES

Picture		
		
Item No	Name	
GT33	门把手	

Picture		
		
Item No	Name	
GT34	46门锁	

Picture		
		
Item No	Name	
GT35	推拉门钩锁	

Picture		
		
Item No	Name	
GT36	推拉门双面锁	

Picture		
		
Item No	Name	
GT37	吸门器	

Picture		
		
Item No	Name	
GT38	6#膨胀管	270个每包

Picture		
		
Item No	Name	
GT39	6.0纱皮条	10KG

Picture		
		
Item No	Name	
GT40	5.0扇纱	10KG

Picture		
		
Item No	Name	
GT41	2mm单边皮条	10KG

Picture		
		
Item No	Name	
GT42	3mm单边皮条	10KG

Picture		
		
Item No	Name	
GT43	3.5mm单边皮条	10KG

Picture		
		
Item No	Name	
GT44	4mm单边皮条	10KG

Picture		
		
Item No	Name	
GT45	5mm单边皮条	10KG

Picture		
		
Item No	Name	
GT46	6mm单边皮条	10KG

Picture		
		
Item No	Name	
GT47	08门皮条	

ACCESSORIES

Picture		
		
Item No	Name	
GT48	直角定位	

Picture		
		
Item No	Name	
GT49	13*18压铸角码	

Picture		
		
Item No	Name	
GT51	三轨边锁	

Picture		
		
Item No	Name	
GT52	三轨轮子	

Picture		
		
Item No	Name	
GT52A	三轨轮子	

Picture		
		
Item No	Name	
GT52C	三轨轮子	

Picture		
		
Item No	Name	
GT53	防撞块	

Picture		
		
Item No	Name	
GT55	防水盖	

Picture		
		
Item No	Name	
GT55B	防水盖	

Picture		
		
Item No	Name	
GT57	平开窗把手	

Picture		
		
Item No	Name	
GT58	平开窗把手	













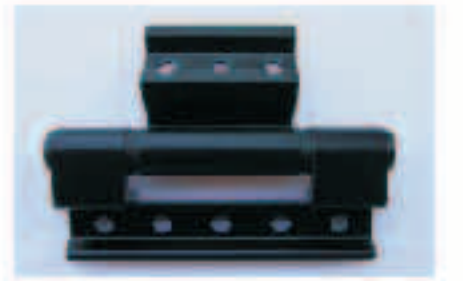

Picture		
		
Item No	Name	
GT59-A	窗寸8	10KG

Picture		
		
Item No	Name	
GT59	窗寸10	10KG

Picture		
		
Item No	Name	
GT60	窗寸12	10KG

Picture		
		
Item No	Name	
GT61	窗寸14	10KG

ACCESSORIES

Picture			Picture			Picture		
								
Item No	Name		Item No	Name		Item No	Name	
GT62	窗寸16		GT63	窗寸18		GT63-A	窗寸20	
Picture			Picture			Picture		
								
Item No	Name		Item No	Name		Item No	Name	
GT64	欧标插销		GT65	10*24 压铸角码		GT66	08门外框铁角码	
Picture			Picture			Picture		
								
Item No	Name		Item No	Name		Item No	Name	
GT67	08门锁		GT68	08门合页		GT69	插锁	
Picture			Picture			Picture		
								
Item No	Name		Item No	Name		Item No	Name	
GT70	76门锁		GT71	76门皮条	10KG	GT72	76门皮条	10KG
Picture			Picture			Picture		
								
Item No	Name		Item No	Name		Item No	Name	
GT73	平开窗支撑		GT74	50平开窗多点锁		GT75	1000系列合页	

ACCESSORIES

Picture			Picture			Picture		
								
Item No	Name		Item No	Name		Item No	Name	
GT76	1000系列合页	10KG	GT77	屏风皮条	10KG	GT78	幕墙皮条	10KG
Picture			Picture			Picture		
								
Item No	Name		Item No	Name		Item No	Name	
GT79	纱窗扣手		GT80	不锈钢大把手		GT80A	不锈钢大把手	
Picture			Picture			Picture		
								
Item No	Name		Item No	Name		Item No	Name	
GT81	10系列皮条	10KG	GT82	镀锌边板	roller shutter	GT83	飞轮盘	roller shutter
Picture			Picture			Picture		
								
Item No	Name		Item No	Name		Item No	Name	
GT84	镀锌拉手	roller shutter	GT85	轴托		GT86	链接钩	roller shutter
Picture			Picture			Picture		
								
Item No	Name		Item No	Name		Item No	Name	
GT87	门锁	roller shutter	GT88	弹簧	roller shutter	GT89	封头	roller shutter

ACCESSORIES

Picture			Picture			Picture		
								
Item No	Name		Item No	Name		Item No	Name	
GT90	镀锌管	roller shutter	GT91	付撑12寸	10KG	GT92	付撑16寸	
Picture			Picture			Picture		
								
Item No	Name		Item No	Name		Item No	Name	
GT93			GT94	PLASTIC SHEET		GT95	高强度拉绳	
Picture			Picture			Picture		
								
Item No	Name		Item No	Name		Item No	Name	
GT96	折叠纱网1.5M		GT96A	折叠纱网2.0M		GT97	铝塑板	
Picture			Picture			Picture		
								
Item No	Name		Item No	Name		Item No	Name	
GT98	门把手		GT100	磨具		GT101	双面胶1mm	
Picture			Picture			Picture		
								
Item No	Name		Item No	Name		Item No	Name	
GT102	角码(夹胶玻璃)		GT103	铝条(夹胶玻璃)		GT104	铝条(夹胶玻璃)	

ACCESSORIES

Picture			Picture			Picture		
								
Item No	Name		Item No	Name		Item No	Name	
GT105	铝条(夹胶玻璃)		GT106	防爆颗粒		GT107	8*80膨胀螺丝	
Picture			Picture			Picture		
								
Item No	Name		Item No	Name		Item No	Name	
GT108	8*120膨胀螺丝		GT109	7X100安装螺丝		GT110	8X100安装螺丝	
Picture			Picture			Picture		
								
Item No	Name		Item No	Name		Item No	Name	
GT111	闭门器		GTM1	隐形纱窗角码		GTM2	橡胶皮	
Picture			Picture			Picture		
								
Item No	Name		Item No	Name		Item No	Name	
GTM3	隐形纱窗把手		GT55B	隐形纱窗磁条		GT127	幕墙角码	
Picture			Picture			Picture		
								
Item No	Name		Item No	Name		Item No	Name	
GT128	幕墙螺丝		GT129	金刚网		GT130	切割片	

ACCESSORIES

Picture			Picture			Picture		
								
Item No	Name		Item No	Name		Item No	Name	
GT131	刀模		GT133	切割机		GT134	铣床	
Picture			Picture			Picture		
								
Item No	Name		Item No	Name		Item No	Name	
GT135	折叠门锁和把手		GT136	折叠门插销		GT137	折叠门14*29角码	
Picture			Picture			Picture		
								
Item No	Name		Item No	Name		Item No	Name	
GT138	折叠门扇胶条		GT139	折叠门框胶条		GT140	折叠门无上轨上单合页吊轮	
Picture			Picture			Picture		
								
Item No	Name		Item No	Name		Item No	Name	
GT141	折叠门无轨上双合页吊轮		GT142	折叠门双边拉手		GT143	折叠门可调单合页下轮	
Picture			Picture			Picture		
								
Item No	Name		Item No	Name		Item No	Name	
GT144	折叠门可调双合页下轮		GT145	折叠门双合页上轮		GT146	折叠门单合页上轮	

ACCESSORIES

Picture			Picture			Picture		
								
Item No	Name		Item No	Name		Item No	Name	
GT147	折叠门边框合页		GT148	折叠门大合页		GT149	折叠门小合页	
Picture			Picture			Picture		
Item No	Name		Item No	Name		Item No	Name	
Picture			Picture			Picture		
Item No	Name		Item No	Name		Item No	Name	
Picture			Picture			Picture		
Item No	Name		Item No	Name		Item No	Name	
Picture			Picture			Picture		
Item No	Name		Item No	Name		Item No	Name	